

**2 Year
Warranty**

forza
POWER TECHNOLOGIES



6-K/K5 - 10K/K5

UPS Online with double conversion technology

Table Of Contents

- Brief Introduction
- Installation
- Operation and operating mode
- Battery maintenance
- Notes for battery disposal and battery replacement
- Trouble shooting
- Appendix 1: Display panel
- Appendix 2: The corresponding form of the LED display
- Appendix 3: Forzatraker Software

1. Brief Introduction

1.1. System and model description

This Online Series is an uninterruptible power supply incorporating double-conversion technology. It provides perfect protection specifically for computer equipment, Communication Systems to computerized instruments.

Its true online double-conversion design eliminates all mains power disturbances. A rectifier converts the alternating current from the utility power to direct current. This direct current charges the batteries and powers the inverter. On the basis of this DC voltage, the inverter generates a pure sinusoidal AC voltage, which is modulated by an isolation transformer and then power the loads.











Computers and Peripherals are thus powered entirely by the UPS. In the event of power failure, the maintenance-free batteries power the inverter.

• This manual is applicable to the following models:

- 1) The EL-6K is a standard model with inbuilt battery, hereinafter called 6K;
- 2) The EL-6KS is a long backup time model, which is able to connect with the external battery bank, hereinafter called 6KS;
- 3) The EL-10K is a standard model with inbuilt battery, hereinafter called 10K;
- 4) The EL-10KS is a long backup time model, which is able to connect with the external battery bank, hereinafter called 10KS;
- 5) The 3EL-15KS is a three-phase input and single-phase output long backup time model, which is able to connect with the external battery bank. Hereinafter called three-phase 15KS.
- 6) The 3EL-20KS is a three-phase input and single-phase output long backup time model, which is able to connect with the external battery bank. Hereinafter called three-phase 20KS.

1.2. Description of commonly used symbols

The following symbols will be used in this manual and may appear during the course of your practical applications. Therefore, all users should be familiar with them and understand their meanings.

Nation and Explanation	
Nation	Explanation
	Alert you to pay special attention
	Caution of high voltage
	Turn on the UPS
	Turn off the UPS
	Idle or shut down the UPS
	Alternating current source (AC)
	Direct current source (DC)
	Protective ground
	Recycle
	Keep UPS in a clear area

1.3. Apparence

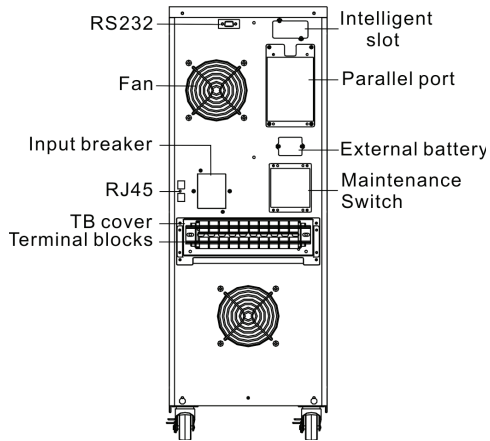

BACK VIEW of 6K(S)

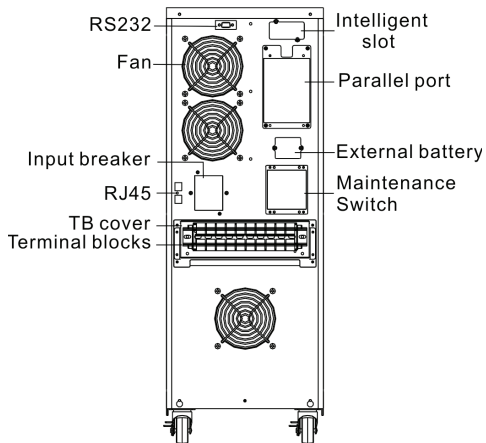

BACK VIEW of 10K(S)

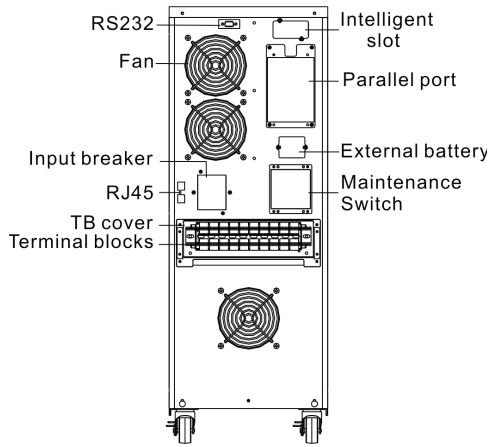

BACK VIEW of three-phase 10K(S)

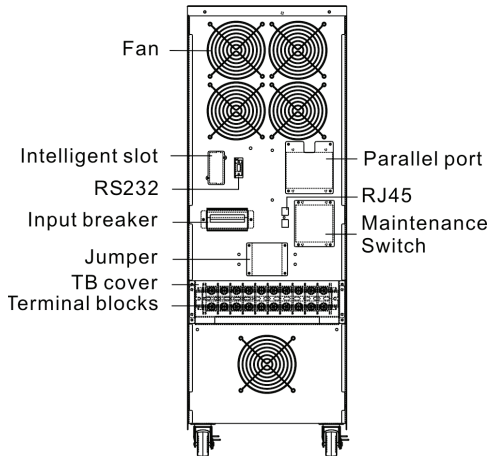

BACK VIEW of three-phase 15KS/ three-phase 20KS

1.4. Product specification and performance

• General Specification

Power Rating	Model	Frequency Hz	Input Voltage	Input acceptable Voltage Range		Battery
				Voltage	Current	Voltage
6kVA/4.2kW	6K	60	220VAC	(176-276)VAC	31A max.	240VDC
6kVA/4.2kW	6KS	60	220VAC	(176-276)VAC	31A max.	240VDC
10kVA/7kW	10K	60	220VAC	(176-276)VAC	50A max.	240VDC
10kVA/7kW	10KS	60	220VAC	(176-276)VAC	50A max.	240VDC
10kVA/7kW	3-phase10KS	60	380/220 VAC	(304-478)VAC	50A max.	240VDC
15kVA/10.5kW	3-phase15KS	60	380/220 VAC	(304-478)VAC	75A max.	240VDC
20kVA/14kW	3-phase20KS	60	380/220 VAC	(304-478)VAC	100A max.	240VDC

Power Rating	Battery Current	Output		Dimensions (WxLxH, mm)	Weight (Kg)
		Voltage	Current		
6kVA/4.2kW	24A max.	120*2/240VAC	25A	300 x 655 x 830	132
6kVA/4.2kW	24A max.	120*2/240VAC	25A	300 x 655 x 830	85
10kVA/7kW	40A max.	120*2/240VAC	42A	300 x 655 x 830	153
10kVA/7kW	40A max.	120*2/240VAC	42A	300 x 655 x 830	98
10kVA/7kW	40A max.	120*2/240VAC	42A	300 x 655 x 830	102
15kVA/10.5kW	60A max.	120*2/240VAC	63A	320 x 720 x 906	170
20kVA/14kW	80A max.	120*2/240VAC	83A	320 x 720 x 906	170

• **Electrical Performance**

Input			
Model	Voltage	Frequency	Power Factor
6K(S)/10K(S)	Single-phase	56Hz-64Hz	>0.98 (Full load)
Three-phase 10KS/15KS/ 20KS	Three-phase	56Hz-64Hz	>0.95 (full load)

Output					
Voltage regulation	Power factor	Frequency Tolerance	Distortion	Overload capacity	Current crest ratio
±5%	0.7lag	Synchronized 56~64Hz in Line mode(AC mode) ±0.1% of normal frequency in Battery mode.	THD<4% Full load (linear load)	105%~130% load transfers to bypass mode after 10 minutes. >130% load transfers to bypass mode after 1 second and shutdown the output after 1 minutes	3:1 maximum

• **Operating Environment**

Temperature	Humidity	Altitude	Storage Temperature
0°~40°	20%~90%	<1000m	-15°~40°

Note:

If the UPS is installed or used in a place where the altitude is above than 1000m, the output power must be derate in use, please refer to the following:

Altitude(M)	1000	1500	2000	2500	3000	3500	4000	4500	5000
Derating Power	100%	95%	91%	86%	82%	78%	74%	70%	67%

Recommended Wiring Table:

1. Principle of wiring design

The goal of wiring design is to find out suitable wire to carry the power to predetermine electrical appliance. Due to the power dissipation on the cable it directly relates with the current it carries, so it is not difficult to understand the current determine by the following factors.

Power capacity consideration

The real power capacity is determined by the user's appliance and the efficiency of the UPS. To be more simple and reliable, assuming the UPS system work with full load all the time. The power capacity to consider can be determine by the UPS system capacity, which is determined by the number of modules.

Power factor consideration

Thanks to PFC (Power factor correction) technology, when the work on inverter output mode, the UPS exhibit unit power factor to mains utility, however, one thing to note is: there is NO PFC under bypass mode, to get most reliability, we recommend using the apparent power to calculate the current.

Voltage consideration

It is obviously that of the same power, the lower voltage, the higher current needs to carry the wire.

2. Recommended wiring table

Base on the factors stated above. The following present a copper wire diameter table for user's reference:

This is a conservative calculation result; user may adjust according real application condition.

Minimum three input voltage with full load is 304V, Minimum single input voltage with full load is 176V for three phases in one phase out UPS.

Minimum single input voltage with full load is 176V for 6-10ks one phase in UPS.

FORZA Series	Wire		Amps	Diameter/AWG	Circuit breaker
6K(S)	Single Phase I/P	L	30A	12AWG /3.3mm ²	32A/230Vac
		N	30A		
	AC OUTPUT	L	30A	12AWG /3.3mm ²	32A/230Vac
		N	30A		
Battery		26A	12AWG /3.3mm ²	30A/300Vdc	
10K(S)	Single Phase I/P	L	50A	8AWG /8.4mm ²	50A/230Vac
		N	50A		
	AC OUTPUT	L	50A	8AWG /8.4mm ²	50A/230Vac
		N	50A		
Battery		44A	8AWG /8.4mm ²	60A/300Vdc	

2. Installation

2.1 Unpacking and inspection

1) Unpack the packaging and check the package contents. The shipping package contains:

- A UPS
- A User Manual
- A Communication Cable
- A Battery Cable (for 6KS/10KS only)

2) Inspect the appearance of the UPS to see if there is any damage during transportation.

Do not turn on the unit and notify the carrier and dealer immediately if there is any damage or lacking of some parts.

2.2 Input and output power cords and protective earth ground installation

1. Notes for installation

1) The UPS must be installed in a location with good ventilation, far away from water, inflammable gas and corrosive agents.

2) Ensure the air vents on the front and rear of the UPS are not blocked. Allow at least 0.5m of space on each side.

3) Condensation to water drops may occur if the UPS is unpacked in a very low temperature environment. In this case it is necessary to wait until the UPS is fully dried inside out before proceeding installation and use. Otherwise there are hazards of electric shock.

Installation and wiring must be performed in accordance with the local electric code and the following instructions by professional personnel.

For safety, please cut off the mains power switch before installation. The battery breaker also needs to be cut off if it is a long backup time model ("S" model).

1) Open the terminal block cover located on the rear panel of the UPS, please refer to the appearance diagram)

2) For 6K(S) UPS, it is recommended to select the UL1015 10AWG(6mm²) wire or other insulated wire which complies with AWG Standard for the UPS input and output wirings.

3) For 10K(S)/3 phase 10KS UPS, it is recommended to select the UL1015 8AWG(10mm²) wire or other insulated wire which complies with AWG Standard for the UPS input and output wirings.

4) For 3 phase 15KS /3 phase 20KS UPS, it is recommended to select the UL1015 6AWG(25mm²) wire or other insulated wire which complies with AWG Standard for the UPS input and output wirings.

Note: Do not use the wall receptacle as the input power source for the UPS, as its rated current is less than the UPS's maximum input current. Otherwise the receptacle may be burned and destroyed.

5) Connect the input and output wires to the corresponding input and output terminals according to the following diagram.

Note: you must make sure that the input and output wires and the input and output terminals are connected tightly. The protective earth ground wire refers to the wire connection between the equipment which consumes electric equipment and the ground wire. The wire diameter of protective earth ground wire should be at least as above mentioned for each model and green wire or green wire with yellow ribbon wire is used.

6) After having completed the installation, make sure the wiring is correct.

7) Please install the leak current protective breaker at the output power distribution panel of the UPS if necessary.

8) To connect the load with the UPS, please turn off all the loads first, then perform the connection and finally turn on the loads one by one. No matter the UPS is connected to the utility power or not, the output of the UPS may have electricity. The parts inside the unit may still have hazardous voltage after turning off the UPS. To make the UPS have no output, power off the UPS, and then disconnect the utility power supply.

9) Suggest charging the batteries for 8 hours before use. After connection, turn the bypass breaker in the "ON" position, the UPS will charge the batteries automatically. You can also use the UPS immediately without charging the batteries first, but the backup time may be less than the standard value.

10) If it is necessary to connect the inductance load such as a monitor or a laser printer to the UPS, the start-up power should be used for calculating the capacity of the UPS, as its start-up power consumption is too big when it is started.

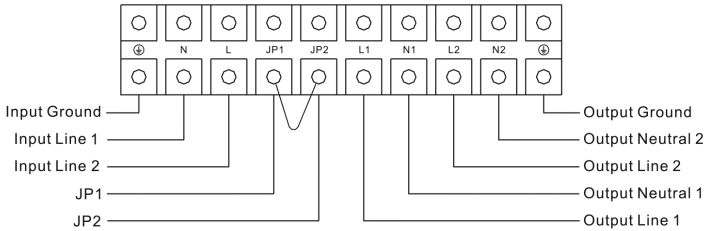

Input and output Terminal Block wiring diagram of 6K(S)/10K(S)

Important notes: On the unit Input board N does not refer to a Neutral input instead Input Line1 is connected here (110/115/120V). L is then used for the secondary Line1 (110/115/120V). If the UPS is used in single mode, JP1 and JP2 must be connected by 10AWG (6mm²). If the UPS is used in parallel mode, the Jumper between JP1 and JP2 must be removed.

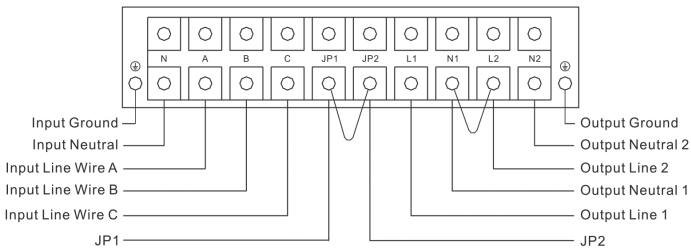

Input and output Terminal Block wiring diagram of three-phase 10KS

Important notes: If the UPS is used in single mode, JP1 and JP2 must be connected by 10AWG (6mm²). If the UPS is used in parallel mode, the Jumper between JP1 and JP2 must be removed.

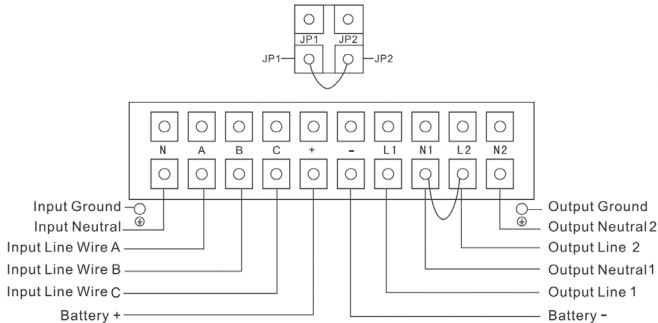

Input and output Terminal Block wiring diagram of three-phase 15K(S)/20K(S)

Important notes: If the UPS is used in single mode, JP1 and JP2 must be connected by 10AWG (6mm²). If the UPS is used in parallel mode, the Jumper between JP1 and JP2 must be removed.

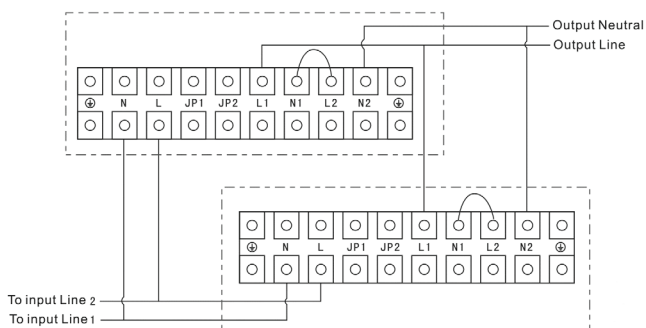

Connection Details of Output Terminals on Parallel mode

Important notes: On the unit Input board N does not refer to a Neutral input instead Input Line1 is connected here (110/115/120V). L is then used for the secondary Line1 (110/115/120V). If the UPS is used in Single Mode, JP1 and JP2 must be connected by 10AWG (6mm²). If the UPS is used in Parallel Mode, the Jumper between JP1 and JP2 must be removed.

• Option 1

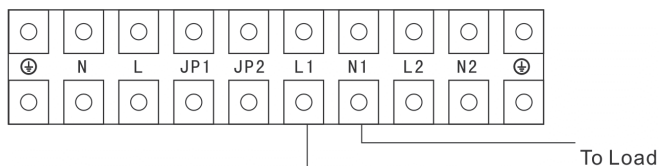
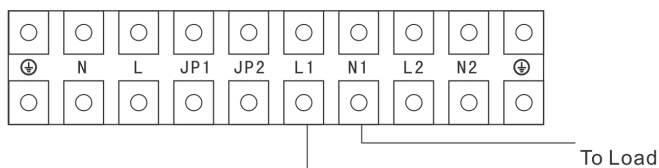

Connection Details of Output Terminals

Connect Output Line 1 and Output Neutral 1 for **120V / 3KVA** Load or connect by 10AWG (6mm²). Output Line 2 and Output Neutral 2 for **120V / 3KVA** Load

Important note: If the UPS is used in Single Mode, JP1 and JP2 must be connected by 10AWG (6mm²). If the UPS is used in Parallel Mode, the Jumper between JP1 and JP2 must be removed.

• Option 2

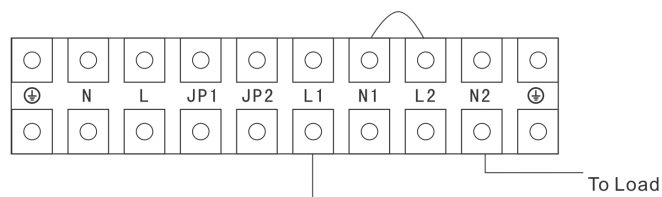

Connection Details of Output Terminals

Connect Output Line 1 and Neutral2 by 10AWG (6mm²) for 240V / 6KVA Load.

Important Note: If the UPS is used in Single Mode, JP1 and JP2 must be connected by 10AWG (6mm²). If the UPS is used in Parallel Mode, the Jumper between JP1 and JP2 must be removed.

2.3 Operating procedure for connecting the long backup time model UPS with the external battery

1. The nominal DC voltage of external battery pack is 240VDC. Each battery pack consists of 20 pieces of 12V maintenance free batteries in series. To achieve longer back time, it is possible to connect multi-battery packs, but the principle of "same voltage, same type" should be strictly followed.

2. The connector of the external battery cable is used to plug into the external battery socket of the UPS; the other end of the external battery cable is made of three open wires with ring terminals to connect with the external battery pack(s). The procedure of installing battery bank should be complied with strictly. Otherwise you may encounter the hazardous of electric shock.

1) A DC breaker must be connected between the battery pack and the UPS. The capacity of breaker must be not less than the data specified in the general specification.

2) Set the battery pack breaker in "OFF" position and connect the 20 pieces of batteries in series.

3) You must connect the external battery cable to the battery first, if you connect the cable to the UPS first, you may encounter the hazardous of electric shock. The positive pole of the battery is connected to the 10KS/3 phase 10KS in parallel with blue and brown wires; the negative pole of the battery is connected to the 10KS/3 phase 10KS in parallel with black and white wires; the green and yellow ribbon wire is connected to the ground of the battery cabinet. For three-phase 15KS/20KS, the connection of battery wire is the same as that of input and output wire, and a green or green and yellow ribbon wire UL1015 6AWG (25mm²) must be connected between the input protective earth terminal and the battery cabinet.

3. To complete the connection by plugging the connector of the external battery cable into the external battery socket of the UPS. Do not attempt to connect any loads to the UPS now. You should connect the input power wire to the right position first. And then set the breaker of the battery pack in the ON position. After that set the bypass breaker in the ON position. The UPS begins to charge the battery packs at the time.

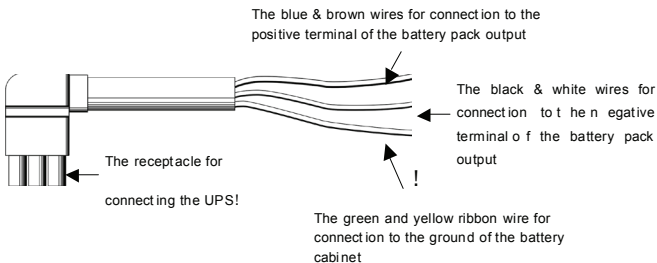

The external battery cable diagram for 6KS/10KS (The cable may vary from different "S" models)

2.4 Parallel operation

1. Brief introduction of the redundancy

N+X is currently the most reliable power supply structure. N represents the minimum UPS number that the total load needs; X represents the redundant UPS number, i.e. the fault UPS number that the system can handle simultaneously. The bigger the X is, the higher reliability of the power system is. For occasions where reliability is highly depended on, N+X is the optimal mode.

As long as the UPS is equipped with parallel cables, up to 3 UPSs can be connected in parallel to realize output power sharing and power redundancy.

2. Parallel installation

- 1) Users need to opt for a standard 25-pin communication cable, which should have 25 cores, corresponding stitches and shield, as the UPS parallel cable. The length of the parallel cable is appropriate to be less than 3 m.
- 2) Strictly follow the stand-alone wiring requirement to perform the input wiring of each UPS.
- 3) Connect the output wires of each UPS to an output breaker panel.
- 4) Disconnect the Jumper on JP1 and JP2 of the terminal block first, and connect each output breaker to a main output breaker and then to the loads.

Note: The requirement of the output wiring is as follows:

- When the distance between the UPSs in parallel and the breaker panel is less than 20 meters, the difference between the wires of input & output of the UPSs is required to be less than 20%;
- When the distance between the UPSs in parallel and the breaker panel is greater than 20 meters, the difference between the wires of input & output of the UPSs is required to be less than 10%.

General Information:

- 1) A maximum of 3 UPS can be connected in parallel mode
- 2) The units in parallel must be same type and rating
- 3) The settings of these devices must be identical
- 4) All parallel output voltage must be the same
- 5) When connecting mains and loads to a parallel system additional distribution has to be taken into account
- 6) Tower series configured as parallel system may use only common mains supply
- 7) An independent battery pack for each UPS
- 8) The communication cable is less than 3 meters

Wiring Diagram for Parallel mode:

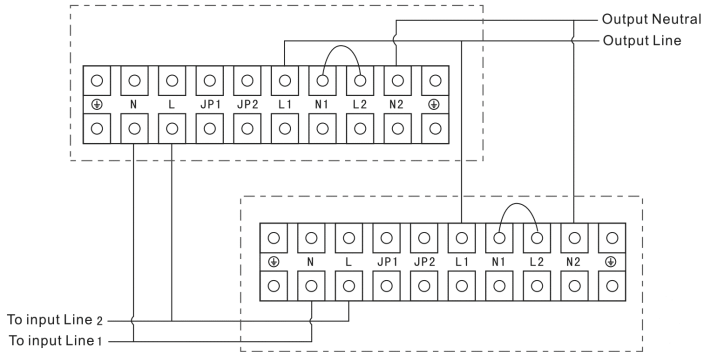

Wiring Diagram for 2 UPS

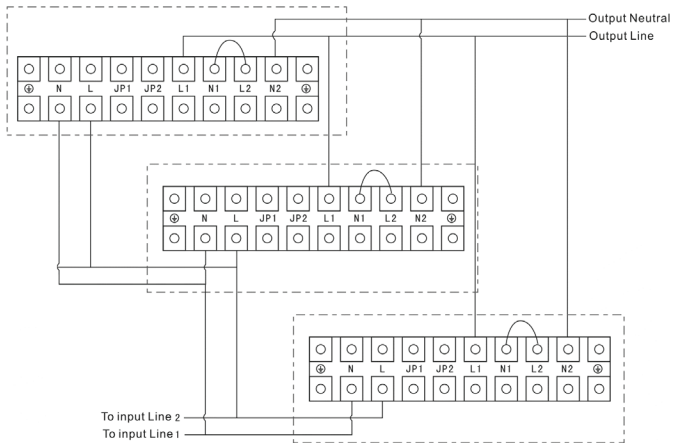

Wiring Diagram for 3 UPS

Installation and Operation

- 1) Connect input and output wires of each UPS. (As shown on wiring diagrams)
- 2) Make sure that each UPS works normal in single mode.
- 3) Disconnect the jumper wire on JP1 and JP2 of the terminal block.
- 4) Connect the parallel communication cable.

It doesn't matter the input/output connection as long as the UPS are connected among them.

- 5) Please refer to the wiring diagram in the general specification page and select suitable breaker.
- 6) Set the maintenance switch from UPS to BPS



- 7) Turn on each UPS in turn and make sure that each UPS works in inverter mode.
- 8) Measure the volt on JP1 and JP2 if the difference is less than 1 volt.
- 9) Measure the volt of each JP2 on each UPS if the difference is less than 5 volts.
- 10) Turn off UPS and set the maintenance switch from BPS to UPS and turn on the UPS to perform the parallel operation.

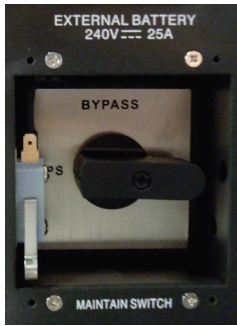

Adding a New UPS:

- 1) Adjust the output volt of the new UPS.
- 2) Disconnect the jumper wire on JP1 and JP2.
- 3) Turn off the UPS system that are running and transfer to bypass mode. Set maintenance switch from UPS to BPS.



- 4) Connect the parallel cable.
- 5) Set the maintenance switch of the new UPS from UPS to BPS



- 6) Connect the input and output wires and turn on all of UPS.
- 7) Measure the volt on JP1 and JP2 if the difference is less than 1 volt.
- 8) Measure the volt of each JP2 on each UPS if the difference is less than 5 volts.

9) Turn off UPS and set the maintenance switch from BPS to UPS and turn on the UPS to perform the parallel operation.

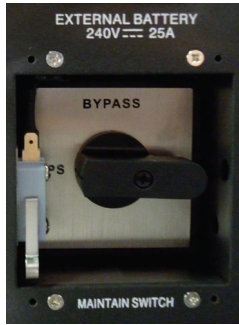

Removing a Single UPS:

- 1) Press the off button twice. The UPS is no output.
 - 2) Turn off the others UPS to bypass mode and set the maintenance switch from UPS to BPS.
 - 3) Turn off the input breaker and output breaker. Make sure that the UPS is shutdown.
 - 4) Remove the parallel cable and input and output wires.
- Set the maintenance switch of the others UPS in parallel from BPS to UPS and turn on the UPS

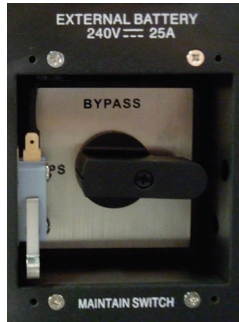

3. Parallel Operation

- 1) To perform the general operation, follow the stand-alone operating requirement;
- 2) Startup: The units transfer to INV mode simultaneously as they start up sequentially in utility power mode;

Shutdown: the units shut down sequentially in INV mode. When the last one completes the shutdown action, each unit will shut down the inverter simultaneously and transfer to bypass mode.

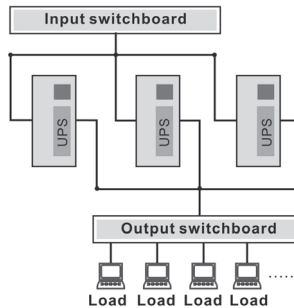

It is easy to operate the equipment, with no previous training. You just need to read through this manual and operate according to the instructions in it. The meaning of the LED indicators, please refer to the appendix 1 "Display panel".

3. Operation and operating mode

3.1 Operation

1. Turn on the UPS with utility power supplied (in Line mode/AC mode)

- 1) After you make sure that the power supply connection is correct, set the bypass breaker and the input breaker in the "ON" position first. At this time the fan rotates and the UPS supplies power to the load via the bypass. The UPS operates in Bypass mode.
- 2) To power on the UPS by simply pressing the "ON" button continuously for more than 1 second.
- 3) When being powered on, the UPS will perform self-diagnosis, with the load/battery level LEDs turned on and then off one after another in ascending order. A few seconds later, the INV LED is turned on; the UPS is already running in Utility Power mode. If the utility power is abnormal, the UPS will operate in battery mode without output interruption of the UPS.

2. Turn on the UPS with no utility power supplied (in Battery mode)

- 1) Press the "ON" button continuously for more than 1 second to power on the UPS. For long back up time model ("S" model), please make sure that the battery breaker is in "ON" position.
- 2) During the course of starting up, the UPS has the same action as if it is connected to utility power except that the utility power LED is not turned on and the battery LED is turned on instead.

3. Turn off the UPS with utility power supplied (in Line mode/AC mode.)

- 1) Press the "OFF" button continuously for more than 1 second to turn off the inverter of the UPS immediately.
- 2) When being powered off, the UPS will perform self-diagnosis, the Load/Battery level LEDs will be turned on and then off one after another in ascending order, then the INV LED will be turned off and Bypass LED will be turned on. The UPS is working in Bypass mode.
- 3) Upon completion of the above to turn it off, output of electric current of the UPS is still present. In order to cut off the output from the UPS, simply cut off the utility power supply and the UPS will perform self-diagnosis, finally not any display is shown on the display panel and no voltage output is available from the UPS output.

4. Turn off the UPS with no utility power supplied (in Battery mode)

- 1) Press the "OFF" button continuously for more than 1 second to power off the UPS.
- 2) When being powered off, the UPS will perform self-diagnosis, the Load/Battery level LEDs will be turned on and then off one after another in ascending order. Finally not any display is shown on the display panel and no voltage is available from the UPS output.

Suggestions: Please turn off the connected loads before turning on the UPS and turn on the loads one by one after the UPS is working in INV mode. Turn off all of the connected loads before turning off the UPS.

3.2 Operating mode

1. Utility power mode

The display panel in utility power mode is shown in the following diagram. The utility power LED and the INV LED are turned on. The load level LEDs will be turned on in accordance with the load capacity connected.



Fig 3-1 The utility power mode

1) If the battery LED is turned on and the utility power LED flashes, it indicates the voltage or frequency of the utility power has exceeded the normal range, the UPS operates in battery mode.

2) If output overloaded, the load level LEDs will be turned on and alarm will keep twice every second. You should get rid of some unnecessary loads one by one to decrease the loads connected to the UPS less than 90% of its nominal power capacity.

Note: Please follow the following steps to connect the generator:

- Activate the generator and wait until the operation is stable before supplying power of the generator to the UPS (be sure that the UPS is in idle mode). Then turn on the UPS according to the start-up procedure. After the UPS is turned on, then the loads can be connected to the UPS one by one.
- The power capacity of the AC generator should be at least twice of the UPS capacity.

2. Battery mode

The display panel in battery mode is shown in the following diagram Fig.3-2. The battery LED and the INV LED are turned on. The displayed number of the battery level LEDs will be turned on in accordance with the battery capacity. Note that the load level LEDs in utility power mode will indicate the level of the battery capacity in battery mode.



Fig 3-2 Battery mode diagram

When the UPS in battery mode, the buzzer beeps once every 4 seconds. If the "ON" button is pressed for more than 1 second, the buzzer will stop beeping. Press the "ON" button once again for more than 1 second to resume the alarm function.

2) When the battery capacity decreases, the number of the battery capacity LEDs turned on will be reduced. If the battery voltage descends to the alarm level, the buzzer will beep once every second to remind the users of insufficient battery capacity and the UPS is soon going to shut down automatically. Then the load operations should be carried out promptly and the loads should be eliminated one by one.

3. Bypass mode

The display panel in bypass mode is shown in the following diagram Fig.3-3. The utility power LED and the bypass LED are lit. The displayed number of the load LEDs will be turned on in accordance with the load capacity connected. The UPS will beep once every 2 minutes in bypass mode.

- 1) The utility power LED flashes, it shows that the voltage or frequency of the utility power has exceeded the normal range of the UPS.
- 2) Other indications on the display panel are the same in utility mode.
- 3) The UPS does not have the backup function when it is in bypass mode. The power used by the load is supplied from the utility power via internal filter and the transformer.

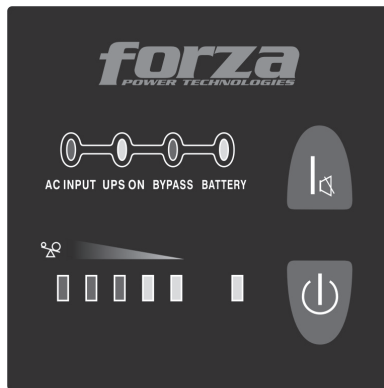

Fig 3-3 UPS bypass mode diagram

4. Abnormality mode

In case the fault LED is turned on when the UPS is in use, it shows that the UPS is operating in abnormal mode. Please refer to the troubleshooting in section 6 for detail.

5. Backup time for the standard model

The backup time of the long backup time model is dependent on the external battery pack capacity and the load level as well as other factors.

The backup time of standard model may vary from different models and load level. Please refer to the following:

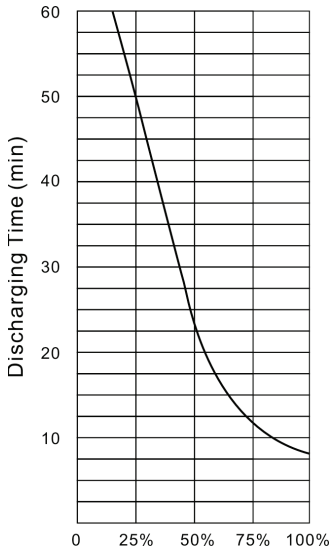

**Load level
backup time of 6kVA**

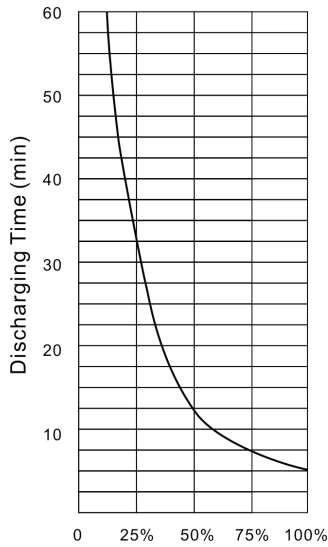

**Load level
backup time of 10kVA**

6. Communication Port

■ Intelligent slot

This series is equipped with an intelligent slot for Webpower (optional accessory) or other optional card to achieve remote management of the UPS through internet / intranet. Please contact your local distributor for further information.

■ RS232 interface

The following are the descriptions and pin assignment of RS232 DB-9 port:

Baud rate: 2400bps

Data bit: 8 bit

Ending bit: 1bit

Parity bit: None

DB-9 pin assignment:

Pin Number	Function Description	I/O
3	Rx	Input
2	Tx	Output
5	Ground	GND

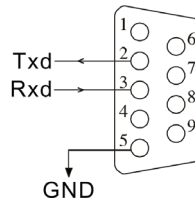

RS232 Interface

■ Optional AS400 interface

This optional AS400 card provides dry contact closure signal "OPEN" or "CLOSE". Following are the pin assignment and the descriptions of AS400 card:

PIN1: UPS failure (normally open, active close)

PIN2: summary alarm PIN3: ground

PIN4: Remote shutdown

- PIN5: Common
- PIN6: Bypass active (relay close)
- PIN7: Battery low
- PIN8: UPS On (relay close)
- PIN9: Utility Power failure (normally open, active close)

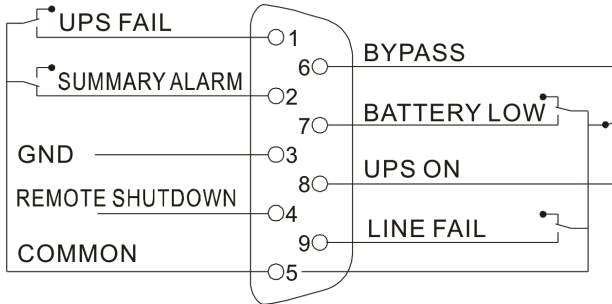

AS400 Interface

4. Battery maintenance

- This series UPS only requires minimal maintenance. The battery used for standard models are value regulated sealed lead-acid maintenance free battery. These models require minimal repairs. The only requirement is to charge the UPS regularly in order to maximize the expected life of the battery. When being connected to the utility power, whether the UPS is turned on or not, the UPS keeps charging the batteries and also offers the protective function of overcharging and over-discharging.
- The UPS should be charged once every 4 to 6 months if it has not been used for a long time.
- In the regions of hot climates, the battery should be charged and discharged every 2 months. The standard charging time should be at least 12 hours.
- Under normal conditions, the battery life lasts 3 to 5 years. In case if the battery is found not in good condition, earlier replacement should be made. Battery replacement should be performed by qualified personnel.
- Replace batteries with the same number and same type of batteries.
- Do not replace the battery individually. All the batteries should be replaced at the same time following the instructions of the battery supplier.
- Normally, the batteries should be charged and discharged once every 4 to 6 months. Charging should begin after the UPS shuts down automatically in the course of discharging, the standard charging time for the standard UPS should be at least 12 hours.

5. Notes for battery disposal and battery replacement

Before disposing of batteries, remove conductive jewelry such as necklace, wrist watches and rings.

2) If it is necessary to replace any connection cables, please purchase the original materials from the authorized distributors or service centers, so as to avoid overheating or spark resulting in fire due to insufficient capacity.

3) Do not dispose of batteries or battery packs in a fire, or they may explode.

4) Do not open or mutilate batteries, released electrolyte is highly poisonous and harmful to the skin and eyes.

5) Do not short the positive and negative of the battery electrode, otherwise, it may result in electric shock or fire.

6) Make sure that there is no voltage before touching the batteries. The battery circuit is not isolated from the input potential circuit. There may be hazardous voltage between the battery terminals and the ground.

7) Even though the input breaker is disconnected, the components inside the UPS are still connected with the batteries, and there are potential hazardous voltages. Therefore, before any maintenance and repairs work is carried out, switch off the breaker of the battery pack or disconnect the jumper wire of connecting between the batteries.

8) Batteries contain hazardous voltage and current. Battery maintenance such as the battery replacement must be carried out by qualified personnel who are knowledgeable about batteries. No other persons should handle the batteries.

6. Trouble shooting

Problem	Possible Cause	Solution
The #1 Fault LED and the #6 LED are turned on, the buzzer beeps continuously	The UPS shutdown due to internal overheat	Make sure the UPS is not overloaded; the air vents are not blocked and the ambient temperature is not too high. Wait for 10 minutes for the UPS to cool down before turning on again. If failed, please contact the distributor or service center.
The #1 Fault LED and the #2 and #5 LED are turned on, and the buzzer beeps continuously	The UPS output is short circuited.	Turn off the UPS. Remove all the loads. Ensure that the load is not failed or the UPS has no internal faults before turning it on again. If failed, please contact the distributor or service center.
The #1 Fault LED and the #4 LED are turned on, the UPS beeps continuously	The UPS shuts down due to its internal fault.	Please contact the distributor or service center.
The #1 Fault LED and the #5 LED are turned on, the UPS beeps continuously	The UPS shuts down due to its internal fault.	Please contact the distributor or service center.
The #1 Fault LED and the #3 LED are turned on, the UPS beeps continuously	Overcharging protection	The charger of the UPS is failed. Please contact the distributor or service center.
The utility power LED flashes	The voltage or frequency of the utility power is out of the input range of the UPS.	The UPS is running in battery mode. To save your data and close the application program. Make sure the utility power is within the input voltage or frequency range permitted by the UPS.

Problem	Possible Cause	Solution
The #1 Fault LED and the #2 LED are turned on, the UPS beeps continuously	The UPS is overloaded or the load equipment is faulty	Check the loads and remove all no-critical equipment. Recalculate the load power and reduce the number of loads connected to the UPS. Check that the loads are not failed.
The #1 Fault LED and the battery LED are turned on, the buzzer beeps every second	The charger of the UPS is defective.	Please contact the distributor or service center.
Battery LED flashes	Battery low or battery not connected	Check the battery. If the battery is damaged, replace the battery immediately and ensure that the battery breaker is in "ON" position.
The utility power is normal, but the UPS can not turn in line mode	Bypass breaker in "OFF" position	Set the bypass breaker in "ON" position.
Battery discharging time diminishes	<p>Battery not yet been fully charged</p> <p>UPS overloaded</p> <p>Battery aged</p>	<p>Keep UPS connected to utility power persistently for more than 10 hours to recharge the batteries again.</p> <p>Check the loads and remove the non-critical equipment.</p> <p>Replace the batteries. Please contact the distributor to obtain the parts and replacement service.</p>
The UPS cannot power on after pressing the ON button	<p>The "ON" button is pressed too briefly</p> <p>The UPS is not connected to the battery or the battery pack voltage is too low.</p> <p>UPS fault</p>	<p>Press the "ON" button for more than 1 second.</p> <p>Check the battery or recharge the battery.</p> <p>Please contact the distributor or service center.</p>

When you contact the service center, please provide the following information:

- Model No. and the serial No. of the UPS;
- The date when the problem arose;
- Complete description of the problem, including the the LED display, alarm warning, and power condition and load capacity. If your UPS is a long backup time model, you may also provide the battery information.

Appendix 1: Display panel

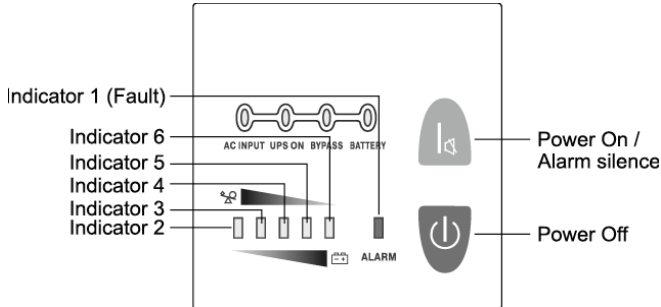

- Power ON/OFF: To turn on the UPS simply by pressing the "ON" button on the front panel continuously for 1 second. Press the "OFF" button on the front panel continuously for 1 second to turn off the UPS.
- Bypass LED (orange LED): Whenever the bypass LED is turned on, it shows that the loading current is supplied directly from the utility power.
- Utility power LED (green LED): Whenever the utility power LED is turned on, it shows that the utility power is normal.
- Inv LED (green LED): Whenever the INV LED is turned on; it shows that the loading current is supplied from utility power or battery via the inverter.
- Battery LED (orange LED): Whenever the battery LED is turned on, it shows that the loading current is supplied from battery via the inverter.
- Fault LED (red LED): Whenever the fault LED is turned on, it shows that the UPS is in abnormal condition.
- #2-#6 LEDs (the #2 LED is orange and the #3-#6 LEDs are green): These LEDs indicate the percentage of the load capacity in utility power mode or battery capacity level in battery mode.

Appendix 2: The corresponding form of the LED display

No	Operating State		LED Display										Alarm Warning
			1 #	2 #	3 #	4 #	5 #	6 #	7 #	8 #	9 #	10 #	
1	Utility Power Mode	0~35% Load capacity						●		●	●		None
2		36%~55% Load capacity					●	●		●	●		None
3		56%~75% Load capacity				●	●	●		●	●		None
4		76%~95% Load capacity			●	●	●	●		●	●		None
5		96%~105% Load capacity		●	●	●	●	●		●	●		None
6	Battery Mode	0~20% Battery capacity		●							●	●	Beep once every sec
7		21%~40% Battery capacity		●	●						●	●	Beep once every 4 sec
8		41%~60% Battery capacity		●	●	●					●	●	Beep once every 4 sec
9		61%~80% Battery capacity		●	●	●	●				●	●	Beep once every 4 sec
10		81%~100% Battery capacity		●	●	●	●	●			●	●	Beep once every 4 sec
11	Bypass mode							●	●	●			Beep once every 2 min.
12	overloaded in utility mode and UPS still in INV mode		●	●	●	●	●	●		●	●		Beep twice every sec.
13	overloaded in utility mode and UPS in bypass mode		●	●					●	●			Continuously beep
14	Utility power abnormal		↑	↑	↑	↑	↑	●	★	↑	↑	↑	↑

15	Overloaded in battery mode, Early-warning	●	●	↑	↑	↑	↑			●	●	Beep twice every sec.
16	Overloaded in battery mode, Cut off the output	●	●									Continuously beep
17	Over temperature	●				●	↑	↑				Continuously beep
18	Inv abnormal	●				●	↑	↑				Continuously beep
19	Output short circuited	●	●			●	↑	↑				Continuously beep
20	BUS voltage abnormal	●			●		↑	↑				Continuously beep
21	Charger or battery failed	●		●		●	↑	↑		★		Continuously beep
22	Battery voltage abnormal	↑	↑	↑	↑	↑	●		●	★		↑
23	BAT SCR failed	●		●			●					Continuously beep
24	Fan abnormal	●	●				●	●	●			
25	Bypass STS failed	●				●	●	●	●			Continuously beep
26	INV RLY failed	●			●		●	●	●			Continuously beep
27	Communication abnormal	●		●	●			↑	↑			

● : Solid ON

★ : Flash

↑ : LED display and alarm warning are dependent on other condition

Appendix 3: Forzatraker Software

Software Installation

Forzatraker software is a new generation of UPS monitoring software, which provides user-friendly interface to monitor and control your UPS system. This unique software provides safely auto shutdown for multi-computer systems while power failure. With this software, users can monitor and control any UPS on the same LAN no matter how far from the UPSs.

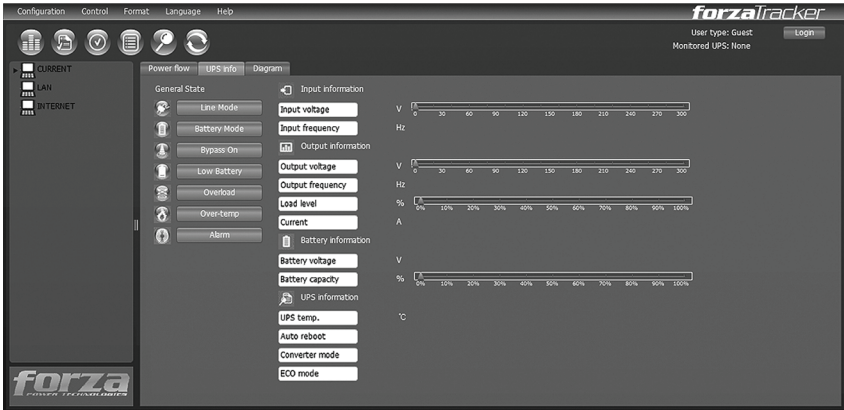

Installation procedure:

1. Go to the website: http://www.forzaups.com/software_download.aspx
2. Choose the type of operation system and follow the instructions on the website to download the software.
3. When downloading all required files from the internet, enter the serial No: 5242-87f6-64re-di8d-986u to install the software (include the hyphens).
4. To access as Administrator enter the password: 111296
5. When your computer restarts, the management software will appear as a green plug icon located in the system tray, near the clock.
6. To access the Forzatraker software as an administrator, you must enter the password "Administrator" (Please note that the "A" must be capitalized).



©2007 Forza Power Technologies. All rights reserved.

Under the copyright laws, this manual may not be copied, in whole or in part, without written consent of Forza Power Technologies.

Forza Power Technologies is a registered trademark. Other company and product names mentioned herein are trademarks of their respective companies. Mention of third-party products is for informational purposes only and constitutes neither an endorsement nor a recommendation. Forza Power Technologies assumes no responsibility with regard to the performance or use of these products. www.forzaups.com