

FORZA

SERVICE MANUAL

EL-3KR

110VAC

General Information

Getting started

If you want to know:

- ✧ **Overview and what special for this UPS**, refer to section **Introduction**.
- ✧ **Replacing Battery Pack**, refer to **Replacing the Battery Pack**.
- ✧ **Open external case**; refer to **Steps to Open the Case**.
- ✧ **Electrical function and principle** refer to **Principle of Operation**.
- ✧ **Whether UPS works properly**, refer to **Alignments**.
- ✧ **What happened to the UPS**, refer to **Trouble Shooting**.
- ✧ **Electrical performance**, refer to **Electrical Spec**.

Conventions

This service manual uses the following conventions to alert you some important information for safe operation and quick working.



Warning: Denotes a procedure or operation, which, if not perform correctly, may result in personal injury. **Be sure not to continue operation until indicated conditions are fully understood and met.**



Caution: Denotes a procedure or operation, which, if not perform correctly, may cause damage to the UPS. **Be sure not to continue operation until indicated conditions are fully understood and met.**



Information and Tips: There are some tips and skills after this symbol. During service operations, these skills are provided by our design engineers which may help you quickly finish your work.

Important Safety Instructions



1. **For qualified service personnel only.**
2. **DO NOT** perform any internal service or adjustment of this product unless another person is capable of rendering first aid and resuscitation is present.
3. Dangerous voltage exists at several points in this product. To avoid personal injury, don't touch any exposed connections or components while UPS is active.
4. Turn off the UPS and disconnect input power cord before removing outside protective cover.
5. AC voltage is always present if the input AC power is still available.
6. High voltage may present at DC capacitors. Before opening the outside cover, wait for at least five minutes after turning off the UPS.
7. Verify input source (voltage and frequency) before service.



1. **DO NOT** make internal batteries short-circuited.
2. If the battery connectors (P02, P01) are disconnected, be sure to plug in the input power cord and the input power is available before re-connect the battery connectors.
3. After service, verify the polarity of batteries, the tightness of all screws and connectors before restarting the UPS.



After opening the cover, please always check the tightness of all wires, connectors, and screws first. Then check if there is any de-colored components inside

INTRODUCTION

For all UPS of this series, they are strictly tested and carefully designed. We always do our best to make our products more reliable and safer, this is also the goal of our company. However, due to the lifetime of electrical components and some unpredictable reasons, there will be unavoidable failures of this UPS. If this situation occurs, service of qualified person is needed. This service manual will guide the technicians to repair and adjust a problematic UPS. If the UPS still does not work properly, please contact with us and we will be glad to solve any problems you met.

Because of the following unique features of this series UPS (Uninterruptible Power System), it is very easy to maintain and service.

- All major power components are put on PCB.
- Minimum numbers of PCB sub-assembly.
- Major parts are simply connected with flexible insulated wires and plugs.
- All PCBs are interconnected with connectors.

STEPS TO OPEN THE CASE

To open the outside case, please follow steps and figures below:

STEP1:

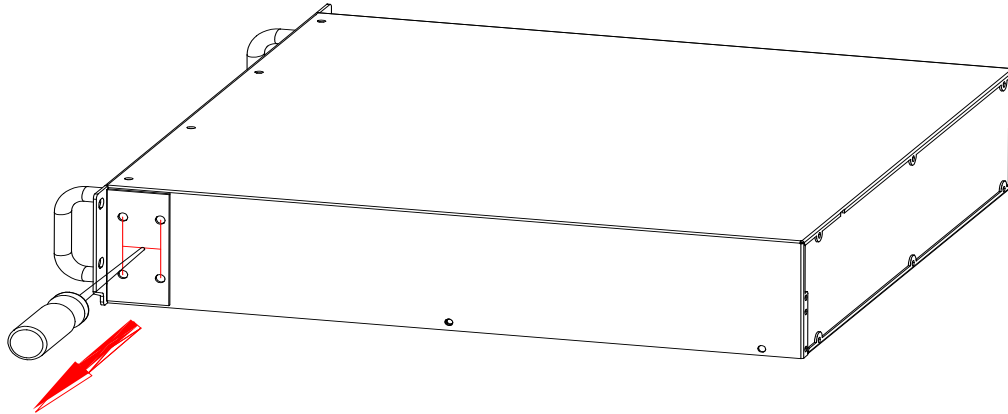

STEP2:

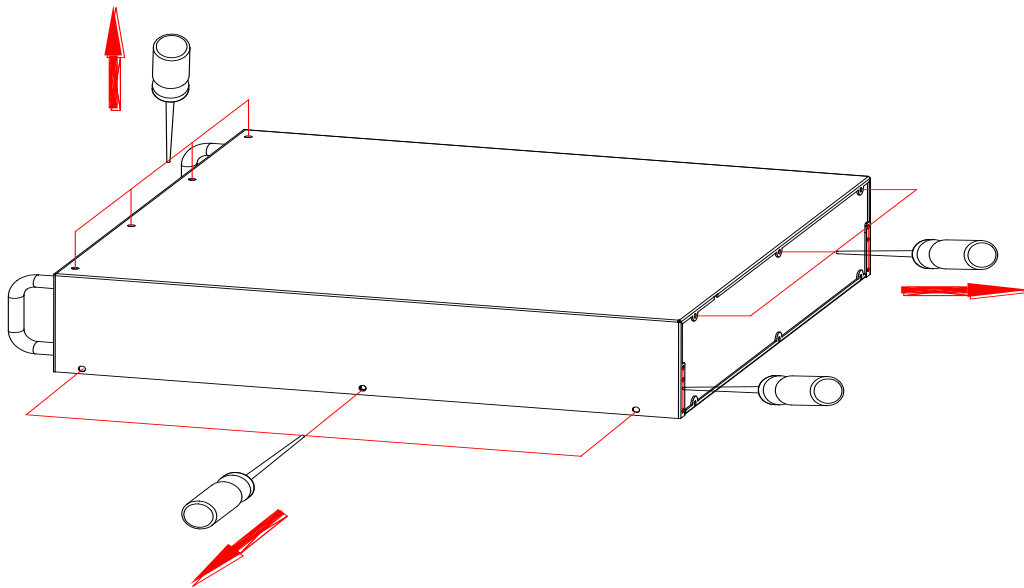

STEP3:

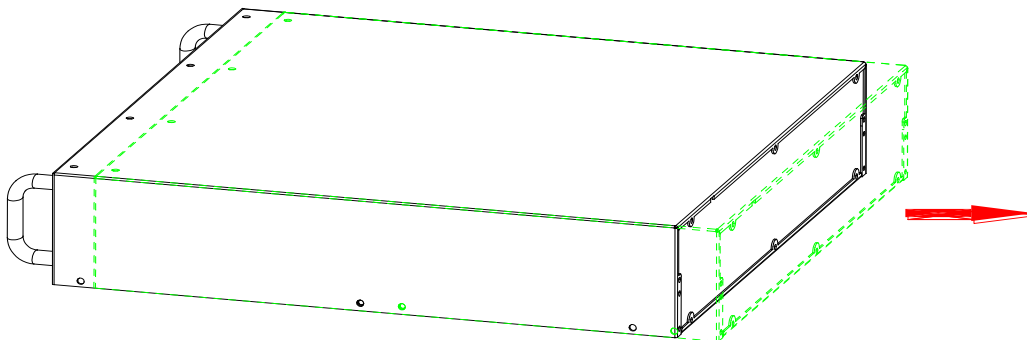

COMPONENTS LOCATION

The main components location of the UPS is shown below:



Warning: Any further operation of service, e.g. removing PSDR PCB, please disconnect at least one of the short battery connection cables shown above to make sure safety of operation.

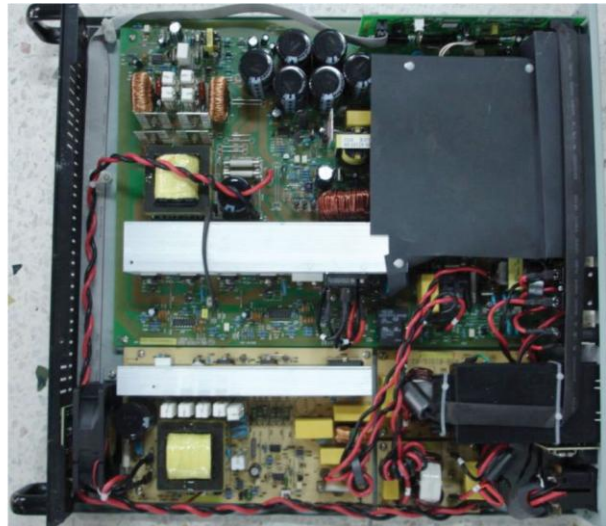
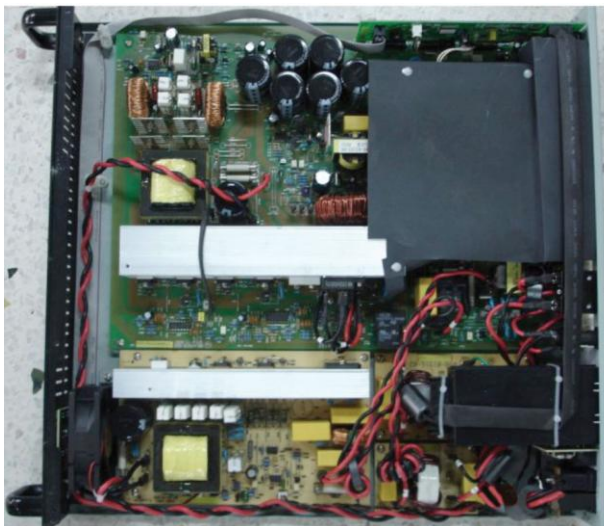
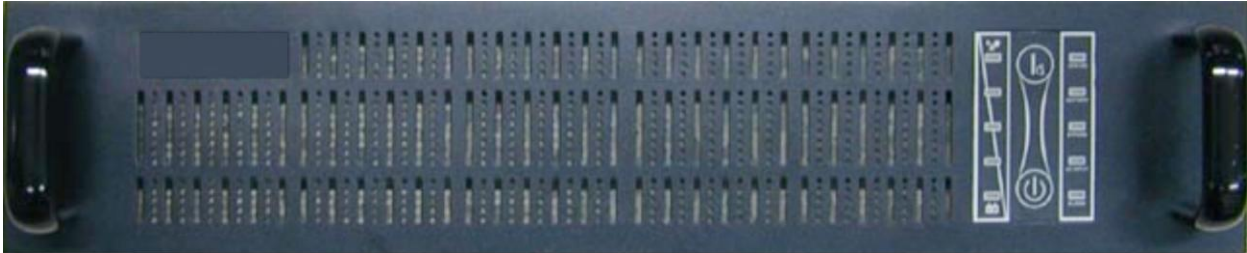

PRINCIPLE OF OPERATION

INTRODUCTION

This EL-3KR high input power factor UPS system contains two major PCB assemblies. They are including:

1. PSDR:	contains major parts of (1) charger, (2) DC power supply, (3) unit power factor correction, (4) DC-DC converter, (5) inverter and (6) output circuits.
2. CNTL:	contains major parts of protection, signaling circuits, regulation and control circuits of inverter.

The simplified schematics in figure1 and figure2¹ shows how the major circuits are connected and illustrates the overall system functions.

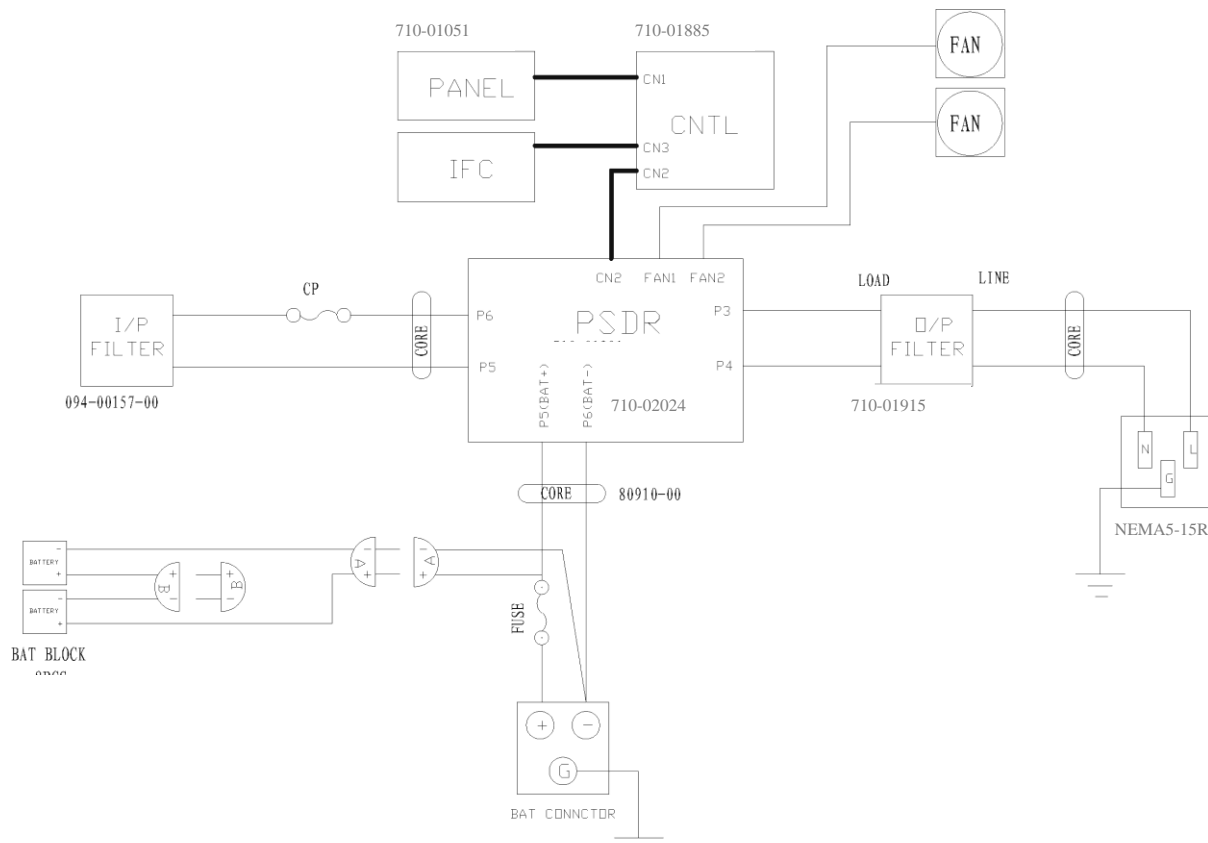

¹ P/N listed in figure 1 and figure 2 are different from customer' s request.

The block diagram in figure 3 shows the UPS at normal operation from left to right. When a protection circuit is triggered or a fault condition occurs, the output supply is transferred immediately from inverter to AC mains by a bypass relay. The operation principle will be explained in later section.

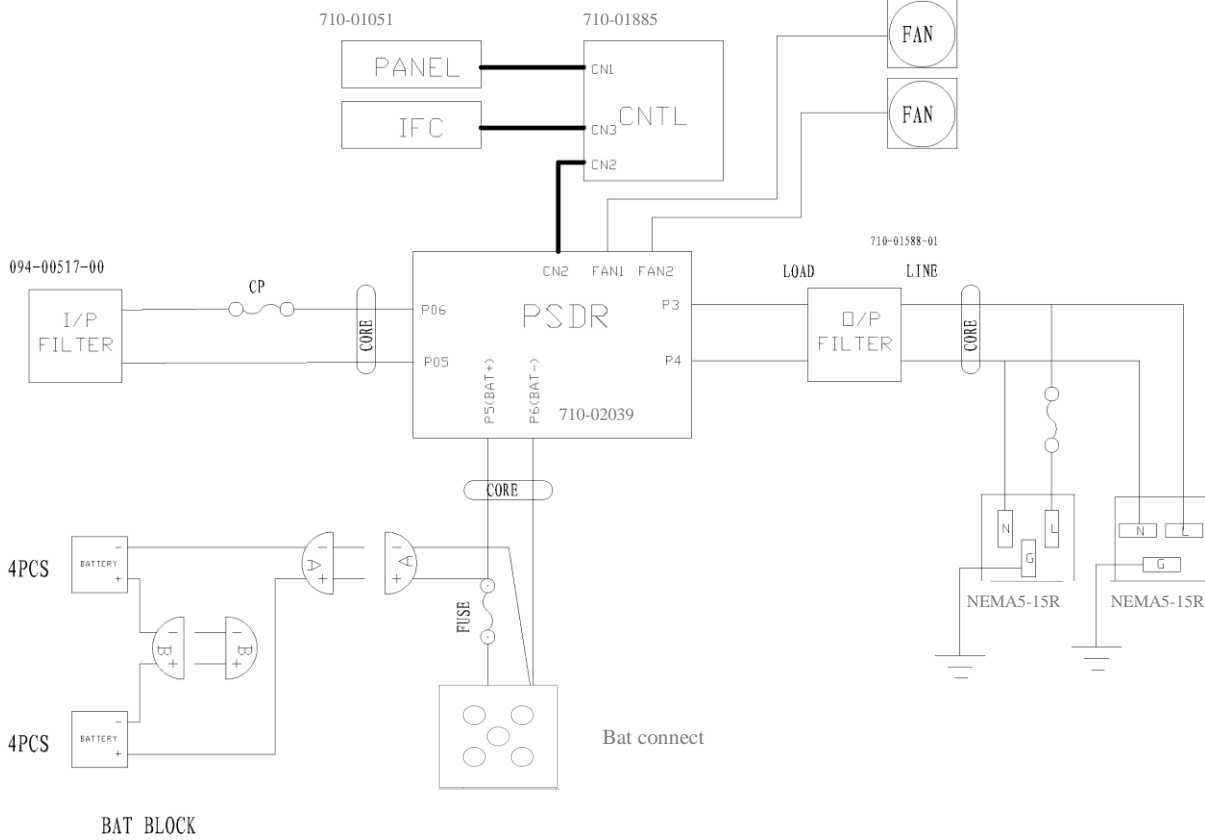

Figure 2: Circuit connection for UL3KVA

Basically, this ON-LINE UPS system utilizes high frequency PWM techniques to achieve high efficient performance. This UPS can deliver a clean, regulated sine-wave output at any load under full load. Each sub-systems are described as below:

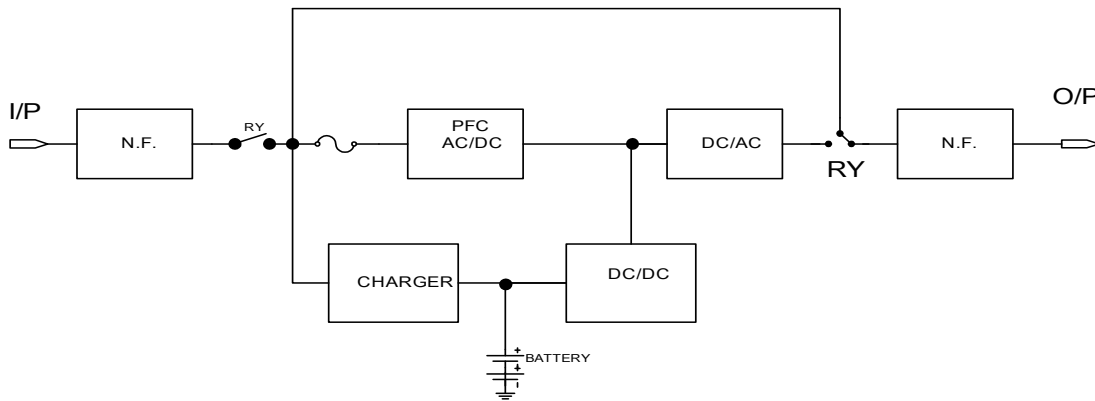

Figure3: Block Diagram for UPS

POWER STAGE (PSDR)

As shown in figure3,the power stage consists of charger, unit power factor correction, DC power supply, DC-DC converter, inverter and output circuits.

Charger Sub-System:

The purpose of charger is to charge and to maintain the batteries at fully charged condition. Refer to figure 4, the voltage flyback switching power supply provides a constant DC voltage (110VDC) for batteries. Besides providing constant voltage, the power supply also limits the current flowing into batteries and therefore protects and prolongs the life time of charged batteries.

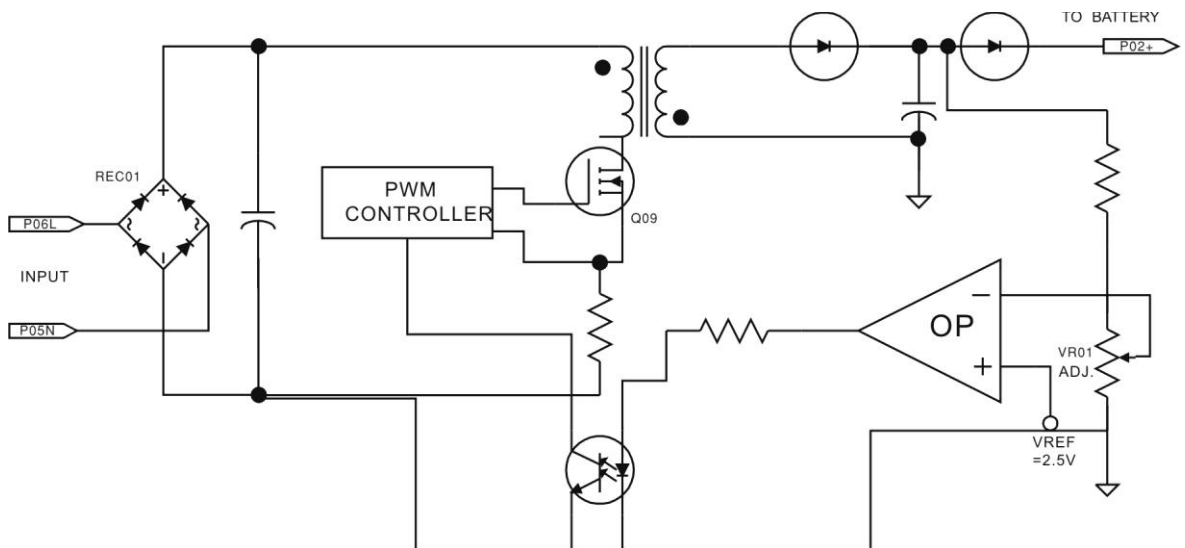

Figure 4: Charger circuit diagram



VR1 in figure 4, which is used to adjust the output voltage of the charger.

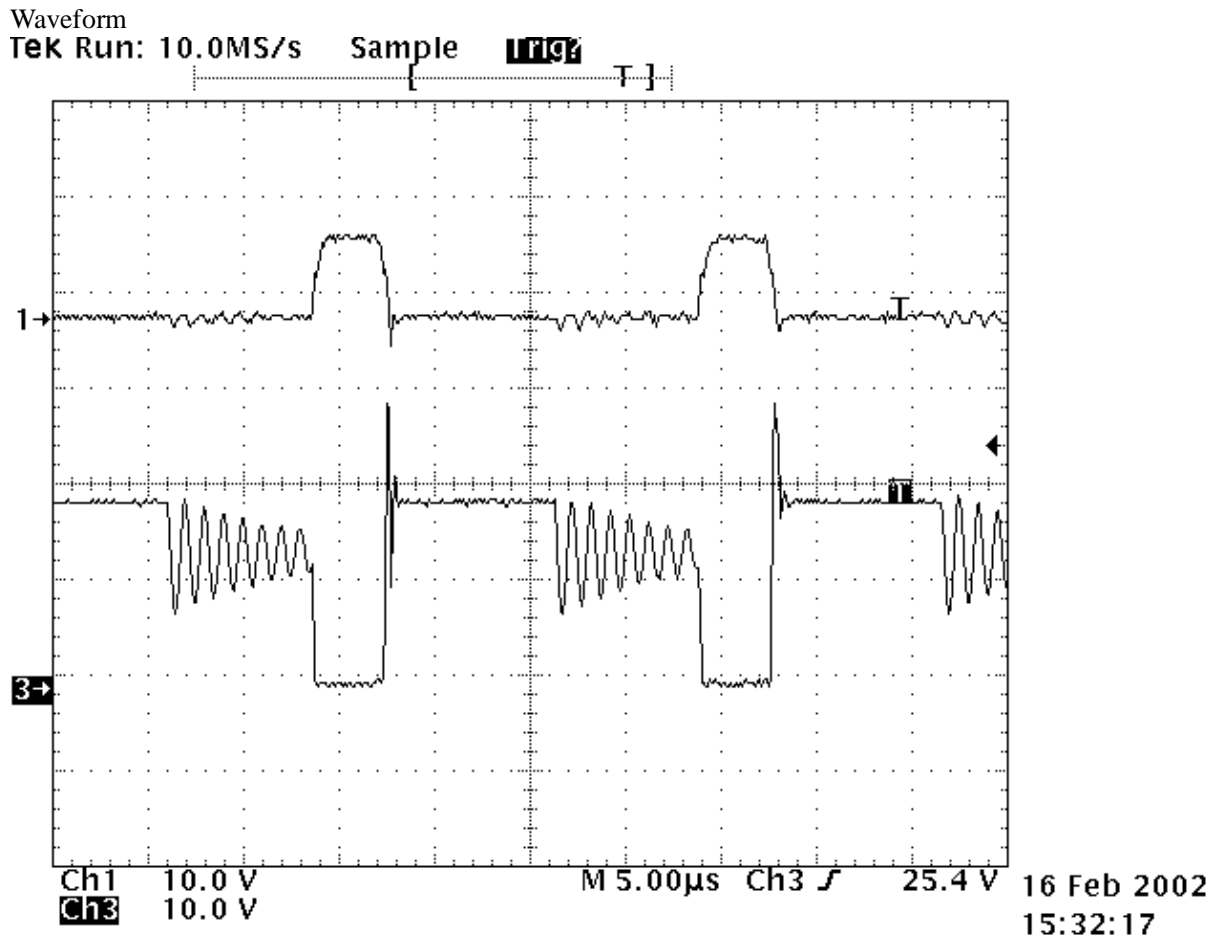

FIG1 CH1 : V_{GS} CH3 : V_{DS}

DC Power Supply Sub-System:

The input of the DC power supply is connected to the battery bus, i.e. the output of the charger. The output of DC power supplies provide +24 VDC for the bias supply of 3854's working voltage, +12 VDC for the bias supply of IC's working voltage, the coil of relay and the fan(s) voltage. 5V is used for IC's working voltage. The DC power supply works only when the 12 VDC regulator supplies V_{cc} to its control IC. To have proper operation of 12 VDC regulator, its input power is controlled by the switch as indicated in figure 5.

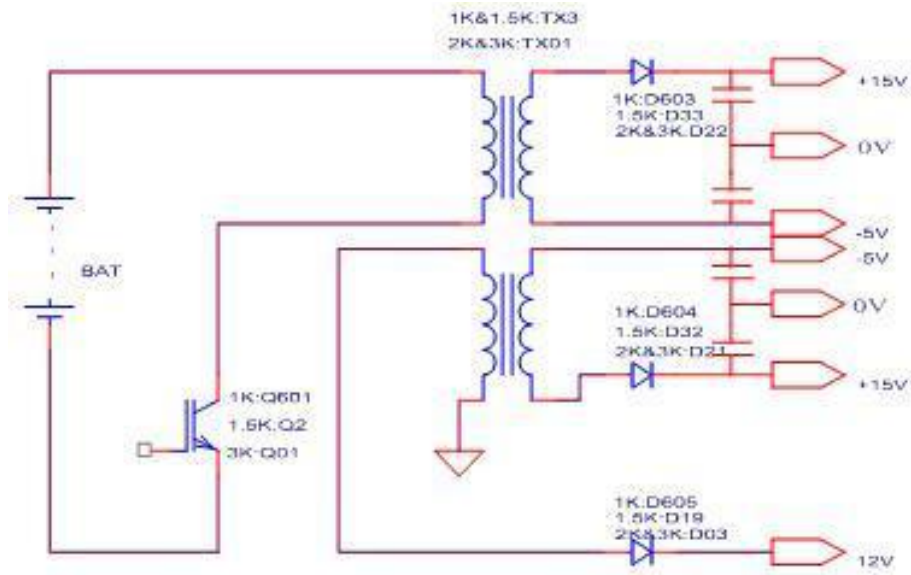

Figure 5: Schematic for DC power supply

Inverter Sub-System:

The UPS converts +, - DC bus voltages to the AC output voltage through an inverter of half bridge configuration. The schematic diagram of inverter is shown in figure 6.

To construct a high frequency (19.2kHz) PWM inverter, the drivers receive switching signals from PWM generation circuit through a pair of photo-couplers to trigger the upper IGBT and the lower IGBT alternately. The output of IGBTs is filtered by a LC circuit to reduce the o/p voltage harmonics distortion.

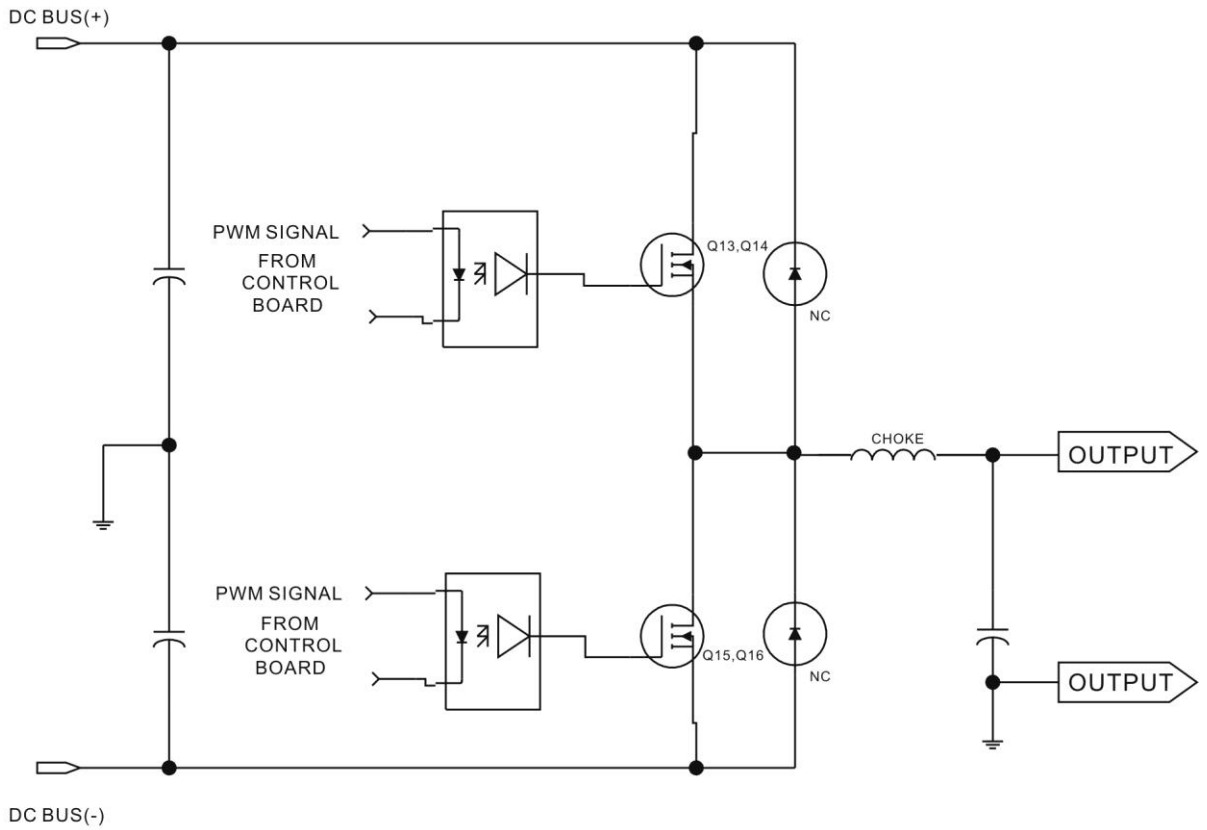

Figure 6: Schematics for inverter

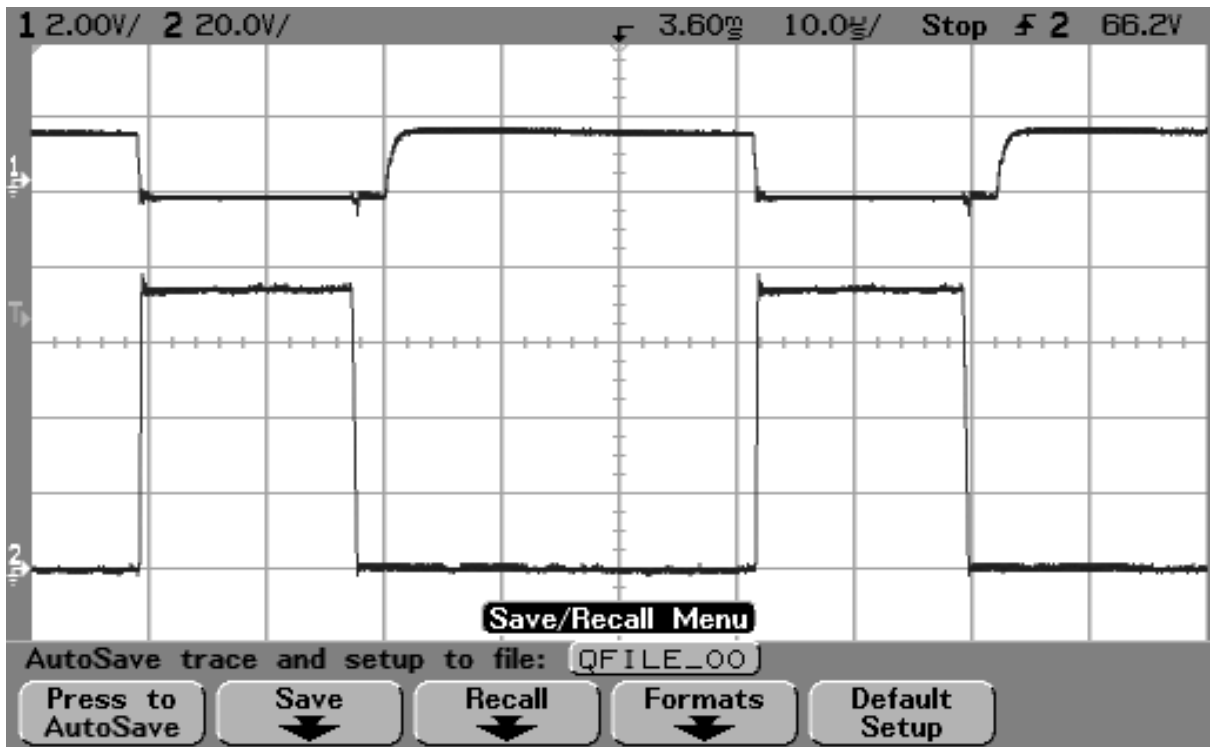

FIG2 CH1 : Vgs CH2 : Vds LINE MODE 110VAC

Output Sub-System:

The bypass relay receives signal from control circuit to switch the output of the UPS from bypass to inverter, and vice versa. The output noise filter circuit blocks EMI noise to the loads.

Input Power Factor Correction Sub-System:

The purpose of power factor correction (P.F.C.) circuit is to make the input current and voltage in phase and therefore achieve a high input power factor near to 1. The schematic is indicated in figure 7.

When the input AC power cord is plugged in, the AC relay is activated and the AC power goes through noise filter to the charger and to the line detector. Both DC buses present voltages at about 1.4 times of input RMS voltage. When the "on" switch is pressed, the P.F.C. circuit is enabled and the DC buses are regulated at ± 170 VDC.

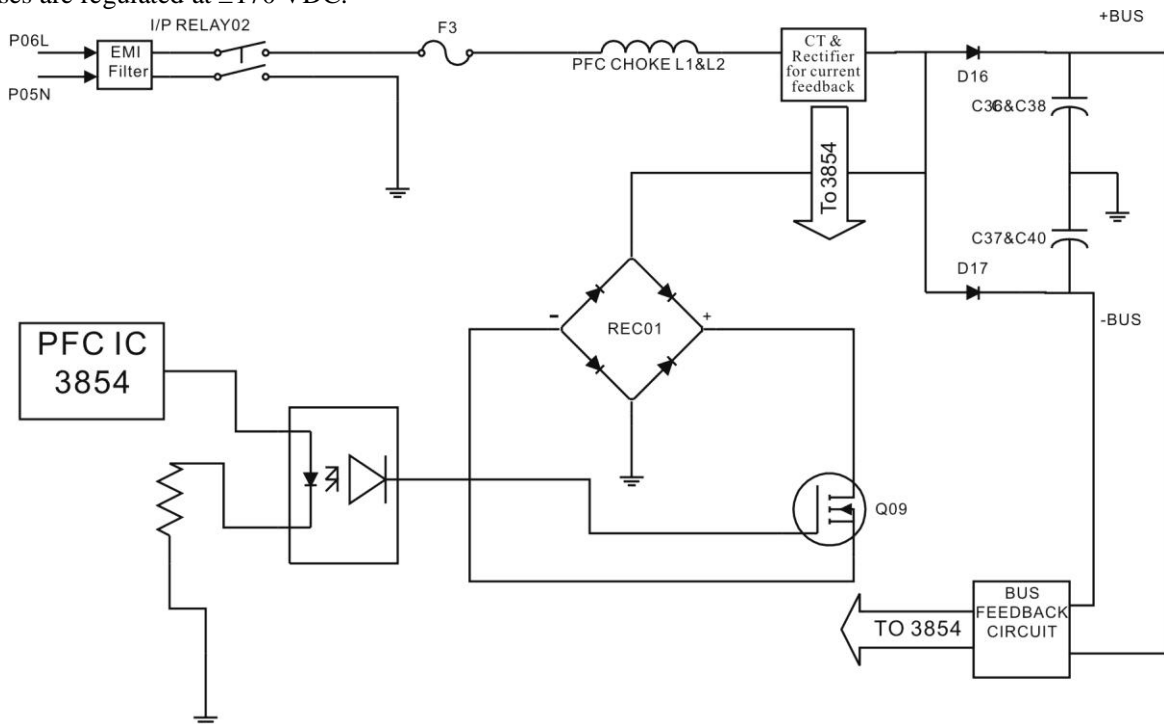

Figure 7: I/P PFC configuration

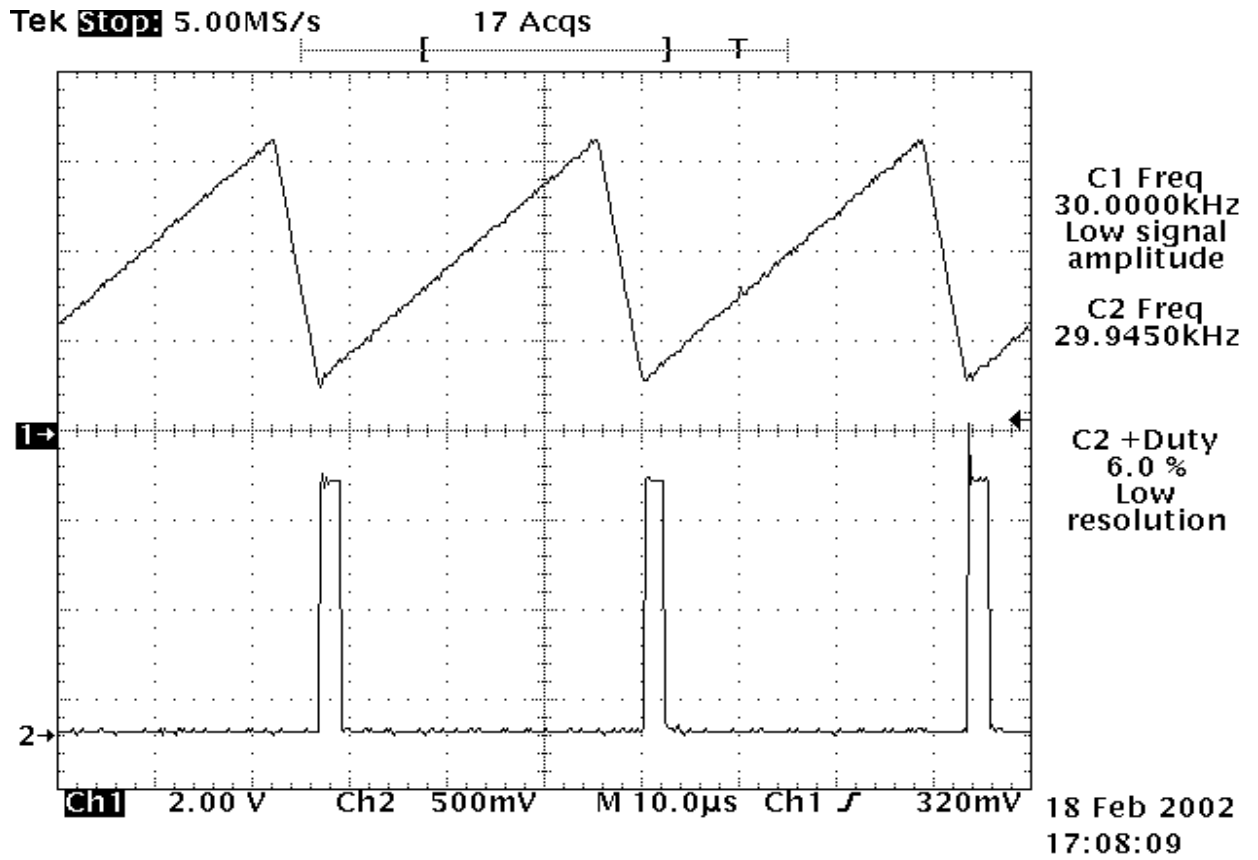

FIG3 CH1 3854PIN14 CH2 3854PIN16

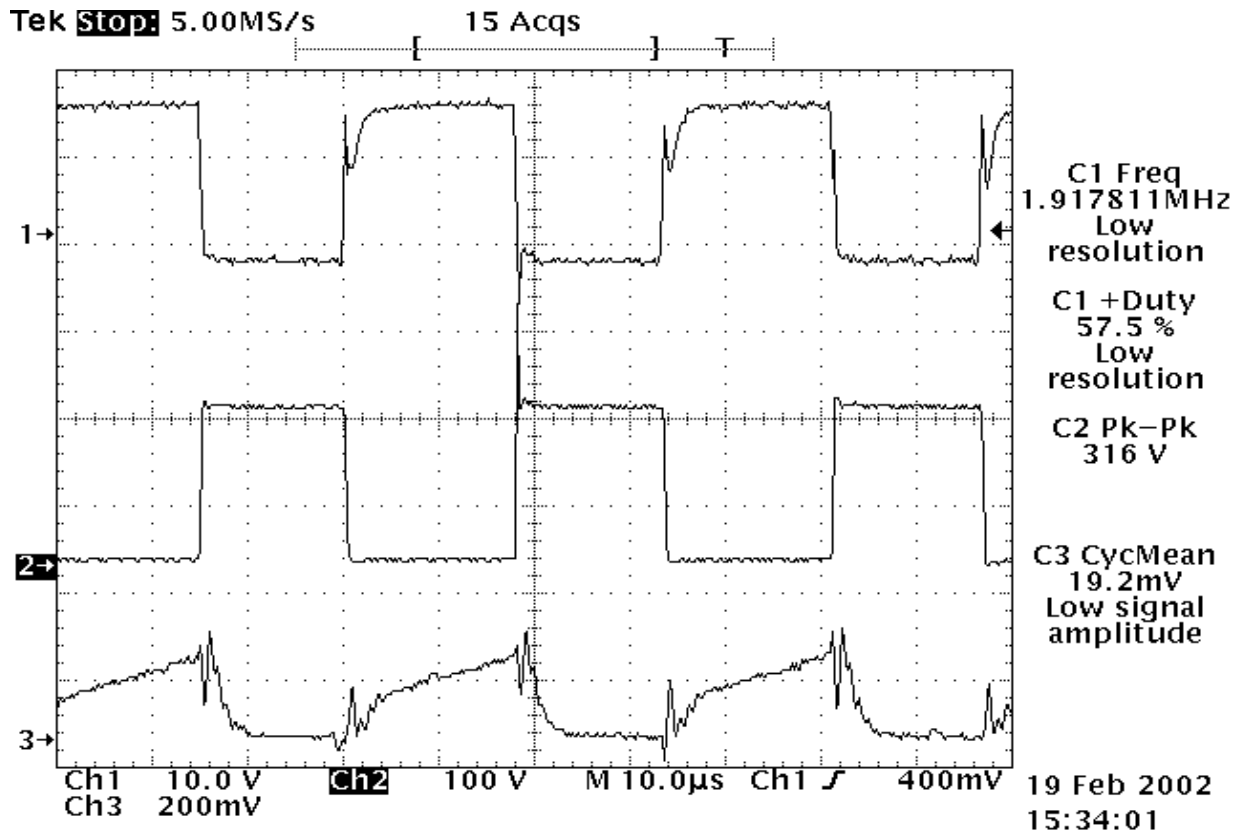

FIG4 CH1 : V_{GS} CH2 : V_{DS} CH3: I_{ds}

DC-DC Converter Sub-System:

The major function of the UPS is to deliver accurate AC power to the loads connected to it whenever the AC line exists or not. In this system, the batteries release the stored energy to supply inverter immediately once AC line lose detected.

Refer to figure 8, the battery voltage is transformed through a push-pull DC-DC converter to $\pm 170VDC$ as DC buses for inverter. When the line fails, the $\pm 170VDC$ DC sources are caught up to supply the power needed by the inverter immediately.

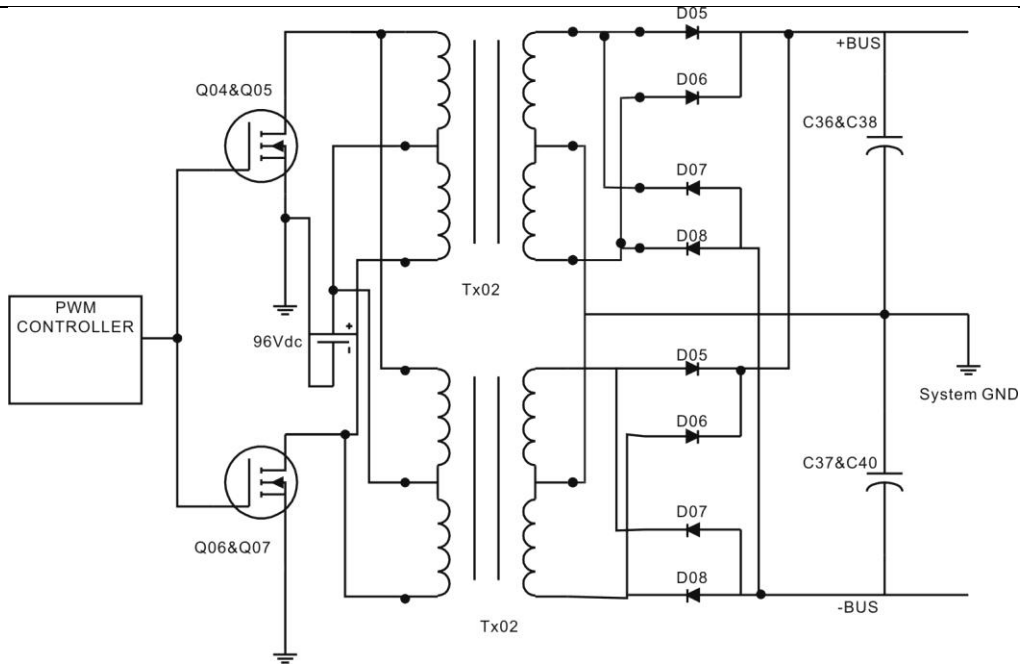
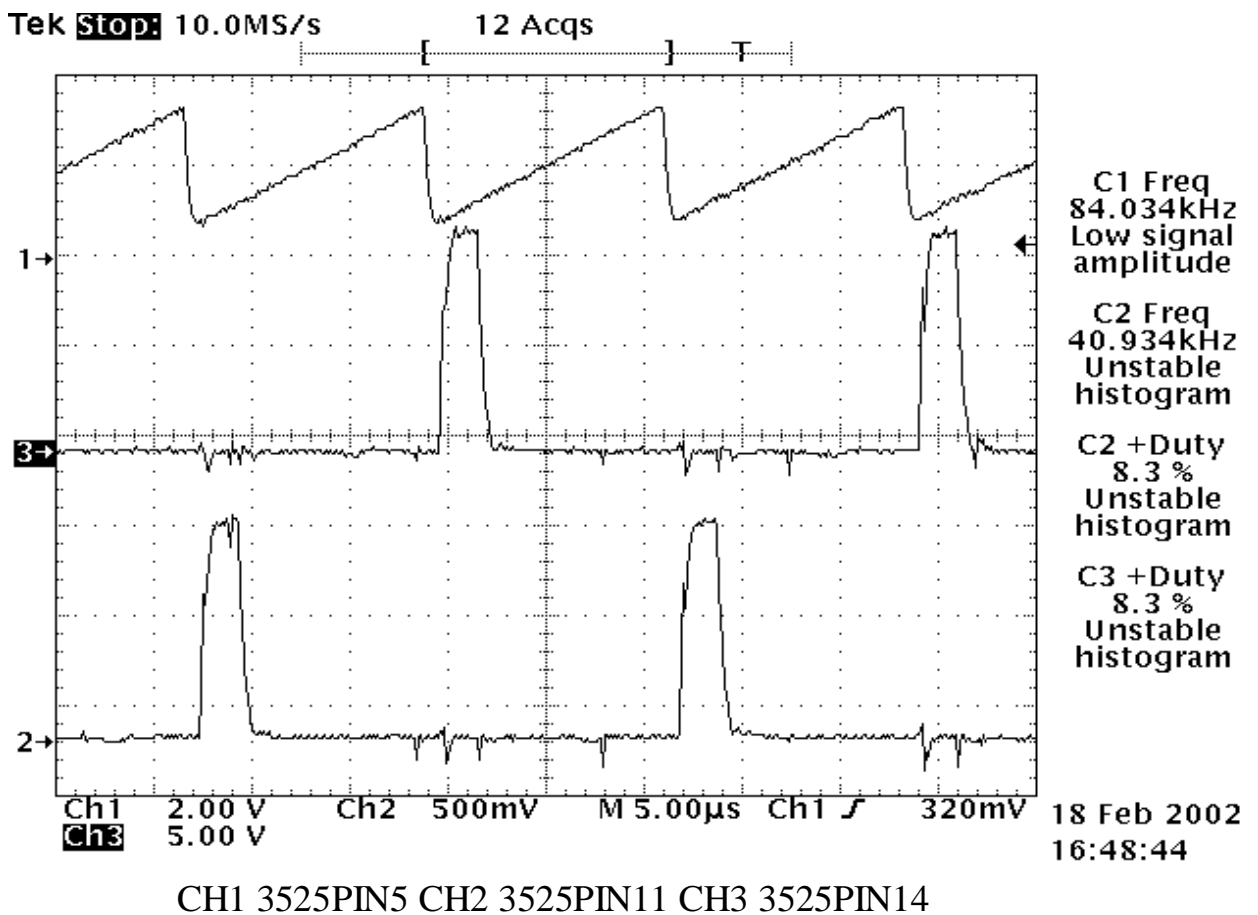

Figure 8: Schematics for DC/DC Booster



MAIN CONTROL PCB ASSEMBLIES (CNTL)

These assemblies are the control center of UPS. It is composed of three major circuits as following.

- (1) Regulation & control
- (2) Protection
- (3) Signaling

REGULATION & CONTROL SUB-SYSTEM:

This portion can be seen as brain of the UPS. It provides the control pulses to the switching elements which deliver power to the output. The sub-system also regulates the output to ensure that the UPS is delivering constant AC voltage to the loads.

The inverter signal is sensed directly by resistor division. It is compared with a reference signal from sine wave generator. The difference of these two signals (error signal) alter the pulse widths of PWM signals which control the duty cycles of switching elements to regulate the output voltage within specification.

In order to avoid unwanted surge current at the transfer of bypass relay, the bypass signal activates the tracking circuit. It matches the inverter voltage with the line voltage by having the amplitude of the reference signal following the variation of line voltage.

When the main is applied and the switch is turned on, a 10-second timer is triggered. The bypass relay stays at bypass position in this time period. At the end of this period, the bypass signal is removed and the relay transfers to inverter output.

PROTECTION SUB-SYSTEM:

The UPS provides the following protection circuits:

1. Overload protection

The load detector senses the load current, i.e. the inverter current, and sends the signal by two paths. In battery mode, the UPS will go to failure mode if overload condition happened. The panel will indicate the fault condition. There are two kinds of protection in our UPS:

- a. **Overload Protection:** The UPS collects the continuous overload signals through CPU switch the bypass relay. If the output load is 110% of rated load (VA ,or Wattage) the UPS keeps running on inverter running for 30seconds. If the output load is higher than 150% of rated load, the UPS transfers to bypass immediately.
- b. **Cycle by Cycle Current Limit:** When output loads sink a high surge current for a short time, a high inverter current is detected and the inverter switches, i.e. the IGBT's, are turned off pulse by pulse to protect themselves from thermal runaway. The output relay stays at inverter output position unless a continuous overload is detected or an abnormal inverter operation occurs.

2. Battery over or under shut down

Upon the battery voltage declines to battery-under level, a signal is generated to cut off the power supply of the whole system, The buzzer becomes silent and all the LED's extinguish. When the utility is coming, the UPS will start up automatically.

In case of the battery voltage is high voltage, the UPS will discharge the battery capacity by way of

DC-DC converter to ensure the battery life. The panel will indicate the fault condition.

3. Inverter output abnormal protection

The inverter failure signal shuts down the inverter immediately, makes the buzzer a continuous alarm, and lights "FAULT" LED. The panel will indicate the fault condition.

"The failure signal latches itself unless SW off or battery is empty".

4. Over temperature protection

The thermal switch detects the temperature of PSDR heat sink. The thermal switch is electrically connected to the CPU. An opened thermal switch is thought as temperature failure by the UPS. The panel will indicate the fault condition.

5. Bus over-voltage protection

To protect any BUS over-voltage condition especially for the half-bridge load. The panel will indicate the fault condition.

Signaling Sub-System:

When the AC line is unable to supply, the batteries release energy inside to supply the inverter immediately. At the same time, the utility failure relay is activated and the buzzer beeps every 4 seconds.

Upon the batteries are discharged to battery-low level, the battery-low signal is activated and the buzzer beeps every 1 second.

Remote shutdown signal is enabled only when the line fails. The signal is connected to the battery detector. It generates battery-under signal to cut off the bias power supply of the UPS system.

Front Panel:

The front panel consists 2 parts: push bottom and display LED set.

The push bottom is used to turn on and off the UPS. LED display indicates the load level (battery mode indicates the battery voltage level) and operation status of the UPS. AC INPUT LED indicates AC line is normal. If the line LED flash, it warns the power source is site fault. BYPASS LED indicates bypass is active. UPS ON LED indicates inverter is working and BATTERY LED indicates the UPS is in battery mode condition.

Besides, when the system works abnormally, the fault LED will light up and the buzzer will beep continuously. In this situation, the panel LED will indicate which part inside the UPS is out of order. The representations of fault conditions are listed as following:

ALIGNMENTS

List below are some test points and procedures when a qualified service person wants to check whether EUT (Equipment Under Test) will works properly. Before beginning following procedures, please *make sure that EUT is OFF and disconnected from Utility.*

TEST ITEM	TEST POINT	TEST AND ADJUSTMENT SEQUENCE	EXPECTED RESULT
Charger Voltage	P02(+) P01(-)	<ol style="list-style-type: none"> 1.Disconnect P02(+) and P01(-) wires from pins respectively. 2.Connect DVM (Set to measure DC) to test points and plug input power cord to utility. 3.Adjust VR1 slowly to expected value. 	<ol style="list-style-type: none"> 1.Cooling fans on back panel begin to rotate. 2. 110 VDC±0.4v
+DC Bus Voltage @ Line Mode	R104Top(+) and GND	<ol style="list-style-type: none"> 1.Connect DVM (Set to measure DC) to test point. 2.Plug input power cord to utility. 3.Press ON bottom for 2 seconds to turn EUT on.. 	+170VDC±10V
-DC Bus Voltage @ Line Mode	R118 Top (+) and GND	<ol style="list-style-type: none"> 4.Waiting for 10 seconds to make sure the Inverter² LED lights. Check reading on DVM 	-170VDC±10V
O/P DC Balance @ Line Mode	O/P socket	<ol style="list-style-type: none"> 1.Keeping UPS on @ Line mode. 2.Connect DC measurement tool³ to O/P socket. 3.Check reading on DVM. 	200mV max.
+DC Bus Voltage @ Backup Mode	R104 Top(+) and GND	<ol style="list-style-type: none"> 1.Disconnect I/P power cord from utility and press OFF bottom for 2 seconds to turn UPS off. 2.Connect DVM (Set to measure DC) to test point. 3.Plug input power cord to utility. 4.Press ON bottom for 2 seconds to turn EUT on.. 5.Waiting for 10 seconds to make sure the Inverter⁴ LED lights. Check reading on DVM 	+170VDC±10V
-DC Bus Voltage @ Backup Mode	R118 Top(+) and GND	Same as previous	-170VDC±10V

² For some models, **Inverter** LED could be labeled as **UPS ON**.

³ DC measurement tool is a low-pass filter. Its schematics is shown on next page

⁴ For some models, **Inverter** LED could be labeled as **UPS ON**.

TEST ITEM	TEST POINT	TEST AND ADJUSTMENT SEQUENCE	EXPECTED RESULT

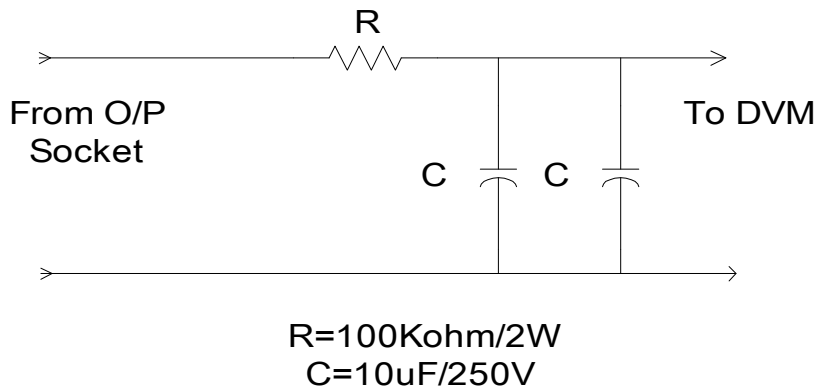

Measurement Tools Schematic for Measuring O/P DC Balance

TROUBLE SHOOTING

Due to careful design and strict tests of our products, fail of UPS seldom occurs. However, once they do fail in some situations, please check them according to **Trouble Shooting Chart**, that will help you solve the most problems on UPS.

Trouble Shooting Chart

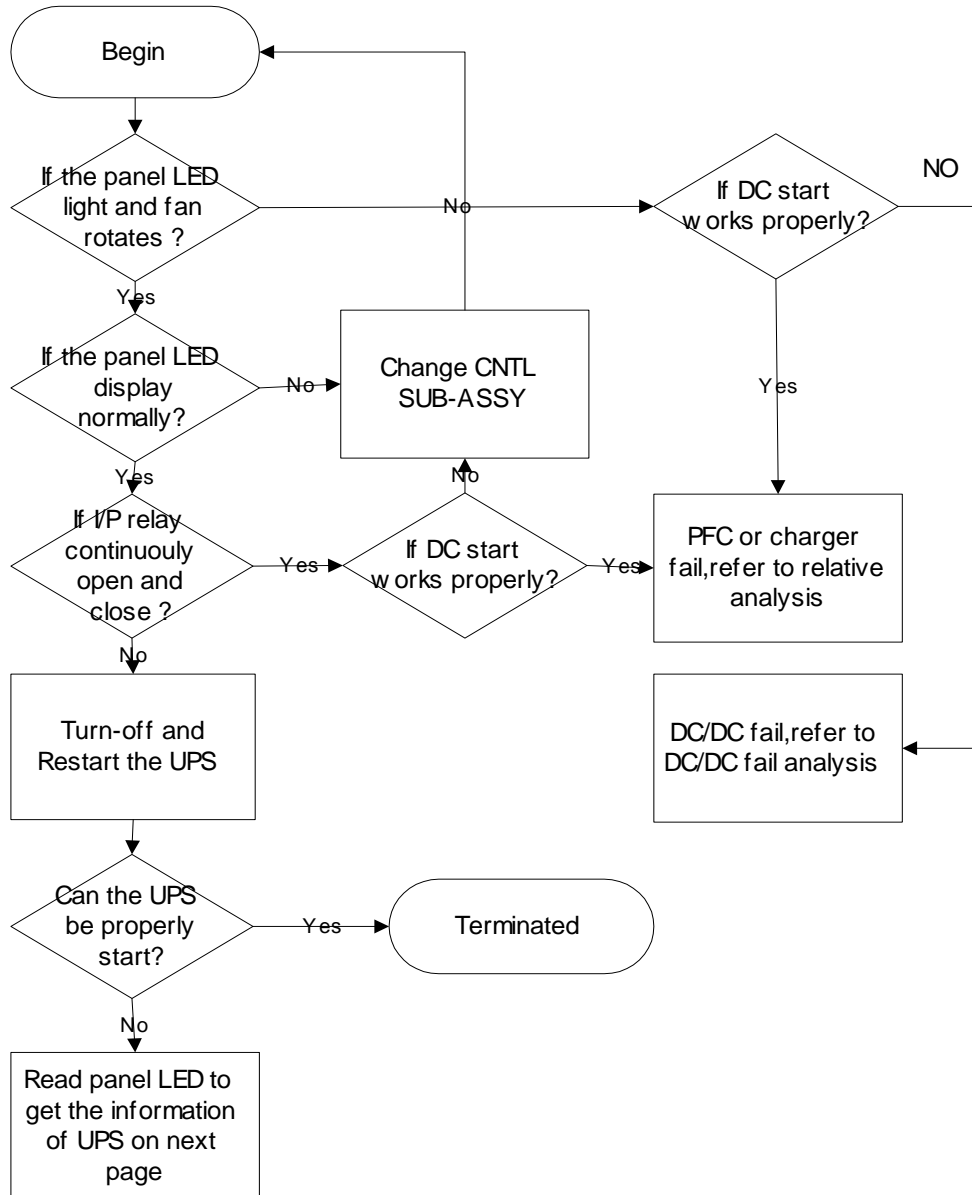

Panel LED Display

Explanation

Bypass Due to Output Overload

Cause: O/P load is larger than rated load in VA or in Wattage.

Strategy: Removed or reduce load connected to O/P socket. On line mode, the UPS will restart automatically. On battery mode, UPS must be OFF in advance and ON again.

Bypass Due to Over-temperature

Cause 1: Ambient Temperature is higher than allowed operation temperature.

Strategy: Reduce ambient temperature or O/P load.

Cause 2: Thermal detection circuit failed.

Strategy: Refer to the thermal detection problem strategy on later pages.

Bypass Due to DC Bus Over-voltage

Cause 1: Some non-fatal misbehavior of UPS.

Strategy: Turn off UPS then Turn it on.

Cause 2: PFC circuit fails.

Strategy: Refer to PFC circuit failure analysis.

Cause 3: DC/DC circuit fails.(In this situation, AC INPUT LED will not light)

Strategy: Refer to DC/DC circuit failure analysis.

Cause 3: Bus voltage feedback circuit problem.

Strategy: Refer to bus feedback loop problem.

Bypass Due to Inverter Failure

Cause 1: O/P short circuit. (In this situation, no power will be transfer to O/P socket.)

Strategy : Remove short circuit condition, turn off the UPS then turn on again.

Cause 2: Inverter circuit failed.

Strategy : Refer to Inverter Circuit failure analysis.

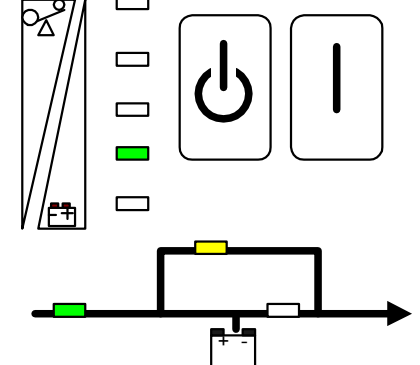
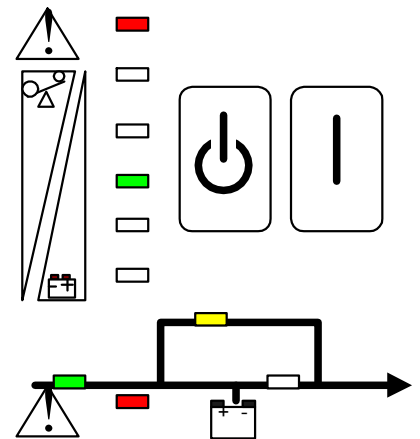
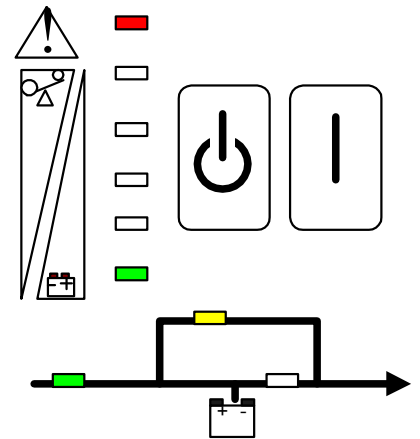
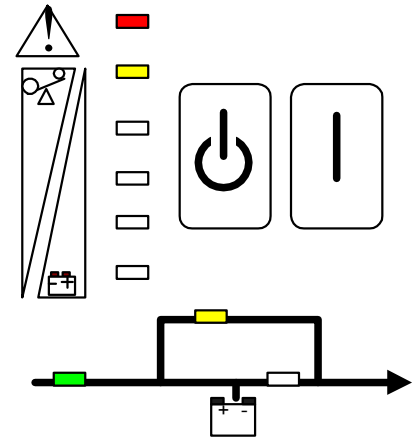

□ **Fault Due to Battery Over-Voltage**

Cause : Charger circuit fail

Strategy :Refer to charger circuit analysis.

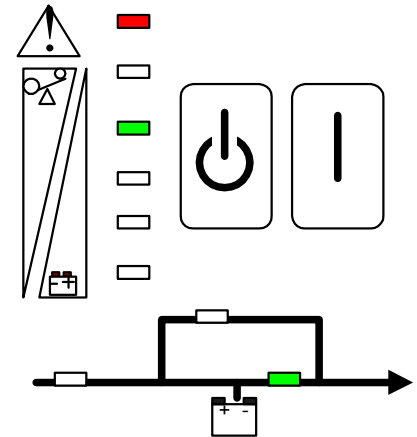

Failure Diagnosis

In this section, some debug skills are listed to help you finding the fail components and problems as soon as possible. Before continuing the following steps listed, we suggest that you should read problem shooting chart in previous section then check the components listed in **Quick Start** to confirm which block is out of order and obey the procedures listed on the following pages to repair them. However, **for the reason of safety, please obey following procedures to begin your work**



High Voltage Danger: Some components inside with high voltage are dangerous, please obey following steps strictly.

- 1.Unplug the power cord from the utility.
- 2.Open outside case shown in the beginning of this manual
- 3.Remove connectors from battery (For some models, unplug battery cabinet connector to UPS)
- 4.Discharge energy in BUS CAPACITORS⁵, and CHARGER CAPACITORS⁶
- 5.Remove all connectors (if required).
- 6.Remove PCB assembly (if required).



Before starting service, some tools are necessary, including: A DMM (Digital Multifunction Meter) meter, screw drivers and discharge resistor(100Ω/10W recommended). A DC power supply (120VDC/3A at least) is recommended for fast and safe diagnosis.



TO DISCHARGE the energy of bus voltage, you can use a 100Ω/10W resistor to contact flange of P01 and upper lead of R104 for +BUS capacitor energy and R118 upper lead for -BUS capacitor energy.



TO DISCHARGE the energy of charger capacitor, you can use a 100Ω/10W resistor contact flange of P02 and P01 for charger capacitor energy, the method is almost

⁵ Capacitor numbered as C36, C37, C38, C40

⁶ Capacitor numbered as C63

same as previous but the discharge points.



DO NOT supply UPS with the mains unless you are sure that you have replaced all defective components.

Quick Start

Before any detail check of UPS, please check the components listed in the following table. This action could help you find problem quickly and make following debug procedures go smoothly.

Related Circuit Block	Components to be checked	Component Type	Fail condition
BAT FUSE	F2, F1	Fuse	open
I/P FUSE (on PSDR)	F3,F4	Fuse	open
U.P.F. Correction	D16, D17, REC02	Diode	short or open
	Q09	IGBT	C-E short or open
Push-Pull Booster	Q04, Q05, Q06 Q07	MOSFET	D-S short or open
	D05,D06,D07,D08	Power Diode	short or open
Inverter	Q14, Q13, Q15, Q16	IGBT	C-E short or open
Charger	Q10	MOSFET	D-S short or open
	D27, D28	Power Diode	short or open
DC Power Supply	Q01	MOSFET	D-S short or open



If the fuse is open, replacing fuse only **DOES NOT** mean you have solved the problem. For most situations, open of fuse is caused by other failure of components, therefore, before restart that UPS, you must find the real failure components and replace them!

P.F.C Analysis:

In this section, some components you could check to see if failure occurs on U.P.F Correction circuit are shown. **BE SURE TO KEEP IN MIND** is that, failure of F3 (OPEN) indicates failure of this block. Please replace all fail to check components then utility can be connected to your UPS.

Step	Checked components	Instrument function	Reference Value	Failed condition
1	F3	Ω	short	open
2	Q09 (D,S)	DIODE	0.46	short or open
3	D16, D17	DIODE	0.44	short or open
4	R66,R206	Ω	47.00	open or value change
5	REC02(+, ~),(~,-)	DIODE	0.46	short or open



If all above list components are replaced and UPS still can't work, try to change U04 (3854) or U06 (TLP250)

Push-Pull DC-DC Converter Analysis

General speaking, the most distinct phenomenon of failure on the section is open of F1 and F2. Knowing this will be very helpful to repair them.

Step	Checked components	Instrument function	Reference Value	Failed condition
1	F1,F2	Ω	short	open
2	Q04,Q05,Q06,Q07 (D,S)	DIODE	0.47	short or open
3	R31,R36, R34,R33	Ω	5.00	open
4	D05,D06,D07,D08	DIODE	0.41	short or open



BE SURE TO use DC fuse with same spec as original ones to replace failure ones, otherwise, unpredictable danger could happen.



If all above list components are replaced and UPS still can't be DC started, try to change TX02 and TX03.

DC/AC Inverter Analysis

Step	Checked components	Instrument function	Reference Value	Failed condition
1	F3, F2, F1	Ω	short	open
2	Q14, Q13, Q16, Q15 (D,S)	DIODE	0.47	short or open
3	R120, R116, R107, R109	Ω	47 Ω	open
5	U11, U10	N.A.	N.A.	



If fail condition stated in item 3 occurs, it is very possible that the corresponding photo couplers are damaged, too. Replacing that IC is recommended.

DC Power Supply Analysis

Step	Checked components	Instrument function	Reference Value	Failed condition
1	Q01	DIODE	0.47	short or open
2	R05	Ω	47	open
3	R08	Ω	0.50	open
4	R06	Ω	1K	open
5	U01 (3845) PIN 5-6 PIN 5-7 PIN 5-8 PIN 6-8	Ω	>1M >1M 1.5k >1M	too low

AC/DC Charger Analysis

Step	Checked components	Instrument function	Reference Value	Failed condition
1	Q10	DIODE	0.49	short or open
2	R75	Ω	47.00	open
3	R89	Ω	0.39 Ω	open
4	U07 (3843) PIN 5-6 PIN 5-7 PIN 4-8	Ω	45k >1M 3.74k	too low
5	D40, D29, D28, D27	DIODE	0.57	short or open
6	C54,C60	Ω visual	open	short deformed



DO NOT make the charger be active when the case is open, this will cause over-heated of TX03, and therefore the other related components will fail again.



As usual, the most possible fail component is Q10, if this indeed happen, please replace not only that component but also R89, R207, D27, R75 and U07. Since failure of Q10 will cause the other components list above fail.

Others

For previous sections, we pay attention to the components on PSDR, however in this section, we are trying to list some possible failure phenomenon not stated before and on control PCB sub-assembly. They are list as following.

Fail for	Phenomenon	Possible components	Comment
Bus over-voltage	1.Bus over-voltage fault alarm and display occur 2.Bus voltage doesn't meet spec.	U06, Q09,	
Inverter	Inverter fault alarm and display occur.	1.Components listed in previous section. 2.U8, U9, U10, U11	2. This IC's are on CNTL PCB
UPS can't start, but not the problem stated before.	1.LED's light, but are active randomly or abnormally. 2.Buzzer beeps abnormally.	U18 (CPU on CNTL)	
Audible problem	Buzzer does not beep at start-up or for alarm.	Q5, BZ1	on CNTL PCB
Start-up	1. UPS is bypass after the mains is on. 2. no response after press ON button.	1.Q01(IRF730) 2.U13	1.on PSDR 2.on CNTL PCB
O/P DC balance	O/P DC balance is out of spec.	1.U06, Q09 (on PSDR) 2.U22 (on CNTL)	1.Bus feedback loop. 2.Auto-balance circuit.



For O/P DC balance problem, it is almost caused by incorrect bus voltage. If this indeed happen, please try to find which mode the problem arise. For example, if it happens under Line mode, you must measure bus voltages to see if they are correct. After doing this, debug the corresponding circuit. If unfortunately, both mode are incorrect, two possible circuits should be check: Bus feedback loop(on PSDR) and auto-balance circuit (on CNTL).

Finish and Test

After you have replaced all defect components on power stage (PSDR), please follow the steps below.

- 1.Connect with control board.
- 2.Connect cable to panel and plug wires of fan into FAN1 and FAN2.
- 3.Supply DC voltage (96-110VDC)/3 Amp (limited current) with DC power supply via P02 and P01. Press the switch on front panel for 2 seconds, you will see "current limit" **for a short time** on the DC power supply for about only 2 seconds, then UPS should be DC started (If UPS does not start successfully, and **All display LED's extinguish, please try above procedure again**). If UPS does not start up for several trying or DC power supply is on current-limit state continuously, there must be some defective components exists. Please follow trouble shooting chart to debug again.
- 4.When everything seems good, press the off switch on panel and remove DC power supply.
- 5.Plug in the power cord and supply UPS with the mains. Buzzer should beep continuously in the mean time. Measure voltage of the charger output(P02, P01), it should be 110V. If not, adjust VR01 to the desired voltage. The fan will rotate also. If there is no apparent problem at this time, connect the batteries via P02, P01, unplug input power cord.
- 6.After fan stops rotating, plug the input power cord again.
- 7.Turn on the switch on panel again and follow the procedure listed in **Alignment part** to adjust the DC offset, and measure voltage on DC bus, output voltage.
- 8.Re-assembly the UPS
- 9.GOOD LUCK !

APPENDIX I: ELECTRICAL SPEC.

I/P Specification

Cold Start	Yes, default frequency = 50 Hz
Acceptable Input Voltage	0-138VAC
Low line transfer	80VAC; $\pm 2\%$ (Full Load)
Line low comeback	85 VAC; $\pm 2\%$ (Full Load)
Line high transfer	138 VAC; $\pm 2\%$
Line high comeback	133 VAC; $\pm 2\%$
Start-up Voltage with Output Power ratings (at nominal input voltage)	60 VAC to 138 VAC; $\pm 2\%$ 3000VA
earth leakage	3.5 mA, maximum (UPS only)
Input power factor	> 0.95
Input frequency	40 Hz to 70 Hz
Input protection type	circuit protector

O/P Specification

O/P Power	
Power (VA)	3000
Power (Watts)	2100
Output Power Factor Rating	0.7
Load Power Factor Range	0.5 lagging to 1.0 (unity)
Output Voltage	110/115/120
Waveform	Sinusoidal
Nominal Voltage	110 VAC
Line Mode Voltage Regulation	$\pm 2\%$ of nominal; no load to full load, resistive & RCD loads
Battery Mode Voltage Regulation	$\pm 2\%$ of nominal; no load to full load, resistive & RCD loads
Transient Response (line mode)	0% -100% -0%; $\pm 9\%$ max. 20% -100% -20%; $\pm 6\%$ max.

APPENDIX II: COMMUNICATION

RS232

The RS232 provides proprietary command sequence for the computer to monitor the line and UPS status and to control the UPS. The data format is listed as following:

PIN TYPE: female
 BAUD RATE : 2400 bps
 DATA LENGTH : 8 bits
 STOP BIT : 1 bit
 PARITY : NONE

The pin assignment and description are listed in the following table and the interface configuration is indicated in figure VI-1. Note that, the computer will control information exchange by a query followed by <cr> (Character Return). UPS will respond with information followed by a <cr> or action. UPS data will be provided at 2400 baud rate and consist of 8 data bits, 1 stop bit, and no parity bit. All the information is provided in ASCII format.

PIN #	Description	I/O type
1,4,6,7,8	not connected	
3	UPS RS232 receiver R X from computer.	input
2	UPS RS232 transmitter to computer	output
5	GND	
9	Wake Up	input

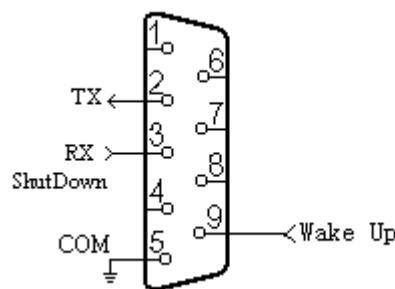

RS232 connection